



MACHINES FOR
CHOCOLATE
& **PASTRY**

MACCHINE PER
CIOCCOLATO E PASTICCERIA

CATALOGUE





L'AZIENDA

ICB Tecnologie srl è specializzata nella produzione di macchine per la pasticceria e macchine per il cioccolato.

L'azienda è presente attivamente sia nel mercato italiano sia in quello internazionale, partecipando alle principali fiere del settore.

Nel corso degli anni, ICB Tecnologie srl è riuscita a farsi apprezzare dagli addetti ai lavori per professionalità, evoluzione tecnologica e costante attenzione alle esigenze della clientela.



THE COMPANY

ICB Tecnologie srl is specialized in the production of machines for pastries and machines for chocolate.

The company is actively present in both the Italian and international market, participating in the major trade fairs.

Over the years, ICB Tecnologie srl has gained the respect of industry experts for its professionalism, technological evolution and constant attention to customers' needs.



LA EMPRESA

ICB Tecnologie srl se especializa en la producción de máquinas para pastelería y máquinas para chocolate.

La empresa se encuentra activa tanto en el mercado italiano como en el internacional y participa de las principales ferias del sector.

Con el transcurso de los años, ICB Tecnologie srl ha logrado el aprecio de los profesionales por su profesionalidad, su evolución tecnológica y su constante atención a los requerimientos de la clientela.



L'ENTREPRISE

ICB Tecnologie srl est spécialisée dans la production de machines pour pâtisserie et machines pour chocolat.

L'entreprise est présente activement autant sur le marché italien qu'international; elle participe aux principaux salons du secteur.

Au fil des ans, ICB Tecnologie srl a réussi à se faire apprécier par les spécialistes du secteur pour sa professionnalité, son évolution technologique et son attention constante aux exigences de la clientèle.



DAS UNTERNEHMEN

ICB Tecnologie srl ist auf die Fertigung von Konditorei- und Schokolademaschinen spezialisiert.

Das Unternehmen nimmt an den bedeutendsten Fachmessen teil und ist im Inland wie im Ausland aktiv.

Dank der hohen Professionalität, dem Augenmerk für die technologische Entwicklung und die ständige Bemühung um eine kundenbezogene Serviceleistung, konnte ICB Tecnologie srl im Laufe der Jahre auch Fachleute für sich gewinnen.

Index









MACCHINE PER IL CIOCCOLATO

MACHINES FOR CHOCOLATE

-  4 Chocotemper Top
-  6 Chocotemper
-  8 ICBelt
-  10 Top Truffle
-  12 ChocoHot
-  16 Scioglichoc Analogici
-  20 Scioglichoc Digitali
-  22 CarapHot
-  24 Warm&Squeeze
-  26 Spraychoc
-  28 Decor-Freeze









MACCHINE PER LA PASTICCERIA

MACHINES FOR PASTRY

-  30 Cook-Matic
-  32 Cook-Matic Piastre/Plates
-  44 CheCrema
-  46 Dosiscream
-  48 Dosiscream Accessori/Accessories
-  50 Chitarra/Guitar
-  54 Linea Digital/Digital Line
-  58 Plurigel
-  60 Spray-Mix

MACCHINE E ATTREZZATURE COMPLEMENTARI

COMPLEMENTARY MACHINES AND EQUIPMENTS

-  62 Rollero
-  64 ICBassina
-  66 Mixers
-  66 ICcrepes
-  67 IC-Flex
-  68 Novaflon
-  69 Carta Uni/Uni baking paper
-  70 Vaschette per gelato/Trays for ice cream
- 70 Teglie/Pans
- 71 Carrelli/Trolleys
- 72 Prodotti chimici professionali



CHOCOTEMPERTOP MADE IN ITALY

Temperatrici da banco
Tabletop tempering machines
Templadoras de mostrador
Tempéreuses sur table
Tischtemperiergeräte

 **CHOCOTEMPER TOP** è la linea di temperatrici da banco, con capacità di 5,5 e 11 Kg, che permettono di temperare il cioccolato in modo professionale come le macchine più grandi, ma con investimenti e ingombri ridotti.

- Solida struttura in acciaio inox.
- Due motori indipendenti, uno per la coclea e uno per l'agitatore, per una maggiore durata nel lungo periodo.
- Coclea rimovibile in acciaio inox per facilitare la pulizia e per cambiare velocemente il cioccolato utilizzato.
- Possibilità di controllare il flusso di cioccolato tramite il pedale.
- Pannello touch-screen con diverse opzioni:
 - Dosaggi automatici per erogare la corretta quantità di cioccolato.
 - Modalità notturna per tenere il cioccolato sciolto, limitando il consumo durante i periodi di non utilizzo.
 - Rotazione contraria della coclea, utile durante la pulizia e per svuotare il beccuccio.

 **CHOCOTEMPER TOP** are tabletop tempering machines with a capacity of 5.5 and 11 Kg, that make it easy to temper chocolate in a professional manner as if using larger machines, but with a space efficient equipment and at lower costs.

- Robust stainless steel structure.
- Two motors, one for the auger screw and the other for the stirrer, for enhanced motor life over the long-term.
- Removable stainless steel auger screw to facilitate cleaning the equipment and for a quick chocolate change.
- Pedal to control the chocolate flow.
- Touch-screen panel with different options:
 - Automatic dosing to dispense the right amount of chocolate.
 - Night-mode to keep chocolate melted and to keep consumption under control when the equipment is not used.
 - Auger screw can rotate in the opposite direction, a highly useful function to clean and to empty the nozzle.

 **CHOCOTEMPER TOP** son templadoras de mostrador, con capacidad de 5,5 y 11 Kg, que permiten templar el chocolate de modo profesional al igual que las máquinas más grandes, pero con inversiones y estorbos reducidos.

- Sólida estructura de acero inoxidable.
- Dos motores independientes, uno para la cóclea y uno para el agitador, para una mayor duración por largo tiempo.
- Cóclea removible de acero inoxidable para facilitar la limpieza y para cambiar rápidamente el chocolate utilizado.
- Posibilidad de controlar el flujo de chocolate mediante el pedal.
- Pantalla táctil con diversas opciones:
 - Dosificaciones automáticas para erogar la cantidad correcta de chocolate.
 - Modalidad nocturna para mantener el chocolate fundido, limitando el consumo durante los lapsos de no empleo.
 - Rotación contraria de la cóclea, útil durante la limpieza y para vaciar la boquilla.

 **CHOCOTEMPER TOP** sont tempéreuses de table, avec capacité de 5,5 et 11 Kg, qui permettent de tempérer le chocolat de façon professionnelle comme les machines plus grandes, mais avec des investissements et dimensions réduits.

- Solide structure en acier inox.
- Deux moteurs indépendants, un pour la vis sans fin et un pour l'agitateur, pour une plus grande durée.
- Vis sans fin amovible en acier inox pour faciliter le nettoyage et pour changer rapidement le chocolat utilisé.
- Possibilité de contrôler le flux de chocolat moyennant la pédale.
- Tableau tactile avec plusieurs options:
 - Dosages automatiques pour doser la juste quantité de chocolat.
 - Modalité nocturne pour maintenir le chocolat fondu, en limitant la consommation pendant la nuit.
 - Rotation contraire de la vis sans fin, utile pendant le nettoyage et pour vider le bec verseur.

 **CHOCOTEMPER TOP** sind Tisch-Temperiergeräte mit einem Fassungsvermögen von 5.5 und 11 Kg, die eine professionelle Schokoladen-Temperierung wie die größeren Maschinen, aber mit kleineren Investitionen und Abmessungen ermöglicht.

- Stabiler Edelstahlrahmen.
- Zwei unabhängige Motoren, einer für die Schnecke und einer für das Rührwerk für eine längere Lebensdauer.
- Entfernbare Edelstahlschnecke für eine einfache Reinigung und einen schnellen Wechsel der verwendeten Schokolade.
- Kontrolle des Schokoladenflusses mit Pedal möglich.
- Touchscreen-Bedienfeld mit verschiedenen Optionen:
 - Automatische Dosierungen für eine Abgabe der richtigen Schokoladenmenge.
 - Nachtmodus, damit die Schokolade aufgelöst bleibt und der Verbrauch während der Stillstandszeiten eingeschränkt wird.
 - Gegenläufige Rotation der Schnecke, die während der Reinigung zweckdienlich ist.



	Chocotemper Top 14.1.CHOCOTOP
	110/240 V
	1.1 Kw
	52 Kg
	48x46x66h cm
	5.5 Kg



	Chocotemper Top-11 14.1.CHOCOTOP11
	110/240 V
	1.75 Kw
	63 Kg
	55x50x72h cm
	11 Kg



Tavola vibrante da banco
Vibrating table
14.1.VT
 54x32x12.5h cm





Tavola vibrante con griglia
Vibrating table with grille
14.1.VT2
 54x32x12.5h cm

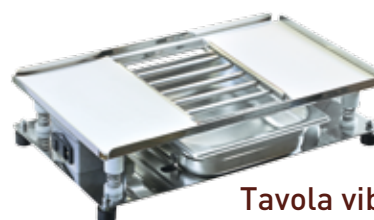

CHOCOTEMPER

MADE
IN
ITALY

Temperatrici di cioccolato *Chocolate tempering machines* Templadoras de chocolate *Tempéreuses de chocolat* Schokoladentemperiergeräte

 **CHOCOTEMPER** è la linea di temperatrici di cioccolato di ICB Tecnologie con vasca da 12 Kg e 24 Kg. Entrambe le macchine possono essere dotate di tavola vibrante, mentre i carrelli ricopritori sono disponibili per Chocotemper 24.

- Solida struttura in acciaio inox.
- Due motori indipendenti, uno per la coclea e uno per l'agitatore, per una maggiore durata nel lungo periodo.
- Coclea rimovibile di serie in acciaio inox per facilitare la pulizia e per cambiare velocemente il cioccolato utilizzato.
- Possibilità di controllare il flusso di cioccolato tramite il pedale.
- Pannello touch-screen con diverse opzioni:
 - Dosaggi automatici per erogare la corretta quantità di cioccolato.
 - Modalità notturna per tenere il cioccolato sciolto, limitando il consumo durante i periodi di non utilizzo.
 - Rotazione contraria della coclea, utile durante la pulizia e per svuotare il beccuccio.

 **CHOCOTEMPER** is the line of chocolate tempering machines from ICB Tecnologie with tank capacity 12 Kg and 24 Kg. A vibrating table can be added to both machines while enrobing belts are available for Chocotemper 24.

- Robust stainless steel structure.
- Two motors, one for the auger screw and the other for the stirrer, for enhanced motor life over the long-term.
- Removable stainless steel auger screw as standard to facilitate cleaning the equipment and for a quick chocolate change.
- Pedal to control the chocolate flow.
- Touch-screen panel with different options:
 - Automatic dosing to dispense the right amount of chocolate.
 - Night-mode to keep chocolate melted and to keep consumption under control when the equipment is not used.
 - Auger screw can rotate in the opposite direction, a highly useful function to clean and to empty the nozzle.

 **CHOCOTEMPER** son máquina templadoras de chocolate de ICB Tecnologie con cubas de 12 Kg y 24 Kg de capacidad. Ambas máquinas pueden ser dotadas de mesa vibrante, mientras que los carros de bañado están disponibles para Chocotemper 24.

- Sólida estructura de acero inoxidable.
- Dos motores independientes, uno para la cóclea y uno para el agitador, para una mayor duración por largo tiempo.
- Cóclea removible de serie de acero inoxidable para facilitar la limpieza y para cambiar rápidamente el chocolate.
- Posibilidad de controlar el flujo de chocolate mediante el pedal.
- Pantalla táctil con diversas opciones:
 - Dosificaciones automáticas para erogar la correcta cantidad de chocolate.
 - Modalidad nocturna para mantener el chocolate fundido, limitando el consumo durante la noche.
 - Rotación contraria de la cóclea, útil durante la limpieza y para vaciar la boquilla.

 **CHOCOTEMPER** sont tempéreuses de chocolat d'ICB Technologie avec capacité de cuve de 12 Kg et 24 Kg. Les deux machines peuvent être fournies d'un plateau vibrant, tandis que les chariots recouvreurs sont disponibles pour Chocotemper 24.

- Solide structure en acier inox.
- Deux moteurs, un pour la vis sans fin et un pour l'agitateur, pour une plus grande durée dans la longue période.
- Vis sans fin amovible de série en acier inox pour faciliter le nettoyage et pour changer rapidement le chocolat.
- Possibilité de contrôler le flux de chocolat moyennant la pédale.
- Tableau tactile avec plusieurs options:
 - Dosages automatiques pour doser la juste quantité de chocolat.
 - Modalité nocturne pour maintenir le chocolat fondu, en limitant la consommation pendant la nuit.
 - Rotation contraire de la vis sans fin, utile pendant le nettoyage et pour vider le bec verseur.

 **CHOCOTEMPER** gehört zur Produktlinie der ICB Technologie Schokoladentemperiergeräte, mit einem Wannen-Fassungsvermögen von 12 Kg und 24 Kg. Beide Maschinen können mit Rütteltisch ausgestattet sein, während die Überziehbänder für Chocotemper 24 erhältlich sind.

- Stabiler Edelstahlrahmen.
- Zwei unabhängige Motoren, einer für die Schnecke und einer für das Rührwerk, für eine längere Lebensdauer.
- Serienmäßige, entfernbar Schnecke für eine einfache Reinigung und einen schnellen Wechsel der Schokolade.
- Kontrolle des Schokoladenflusses mit Pedal möglich.
- Touchscreen-Bedienfeld mit verschiedenen Optionen:
 - Automatische Dosierungen für eine Abgabe der richtigen Schokoladenmenge.
 - Nachtmodus, damit die Schokolade aufgelöst bleibt und den Verbrauch während der Stillstandszeiten eingeschränkt wird.
 - Gegenläufige Rotation der Schnecke, die während der Reinigung zweckdienlich ist.



Chocotemper 12 kg
14CHOCOTEMPER12



380/400 V



2.5 Kw



159 kg



52x80x154h cm



12 Kg



Chocotemper 24 kg
14CHOCOTEMPER24



380/400 V



3.0 Kw



185 kg



62x90x154h cm



24 Kg



Tavola vibrante riscaldata
Heated vibrating table

14.1.VT12

14.1.VT24



Nastro ricopritore per Chocotemper 24 Kg
Enrobing belt for Chocotemper 24 Kg
Cinta de bañado para Chocotemper 24 Kg
Ruban recouvreur pour Chocotemper 24 Kg
Überzugsband für Chocotemper 24 Kg

 La temperatrice di cioccolato Chocotemper 24 può essere fornita con **ICBELT**, un nastro ricopritore a velocità regolabile, indicato per ricoprire prodotti di pasticceria e pralineria, suddiviso in 3 sezioni.

- Prima sezione: area di carico, la quale può essere fermata in modo da poter posizionare i prodotti da ricoprire.
- Seconda sezione: area di ricopratura, in cui i prodotti vengono ricoperti col cioccolato:
 - Sistema di vibrazione e soffiatore, ad intensità e temperatura regolabile, per rimuovere il cioccolato in eccesso e facilitare le operazioni di pulizia della rete metallica.
 - Tagliacode a velocità e senso di rotazione variabile per rifinire ogni tipologia di prodotto.
 - 2 accessori disponibili: ricopritore parziale e ricopritore della parte inferiore del prodotto.
- Terza sezione: area di scarico, in cui i prodotti ricoperti vengono posizionati sull'apposita teglia.

 The chocolate tempering machine Chocotemper 24 Kg can be supplied with **ICBELT**, an adjustable speed enrobing belt, suitable for coating pastries and pralines, divided into 3 sections.

- First section: loading area. It can be stopped to place on it the products to be enrobed.
- Second section: enrobing area. Products are coated with chocolate.
 - Vibrating and blowing system. Adjustable intensity and temperature. Removes excess chocolate and makes it simple to clean the metal mesh.
 - Smear-cutting device with adjustable speed and direction of rotation to give the final touch to any kind of product.
 - 2 accessories available: Partial coater and coater of the bottom side of the product.
- Third section: unloading area. Already coated products are placed on the tray.

 La templadora de chocolate Chocotemper 24 puede suministrarse con **ICBELT**, una cinta de bañado a velocidad regulable, indicada para bañar productos de pastelería y de pralinería, dividida en 3 secciones:

- Primera sección: área de carga, la misma que puede ser detenida para poder posicionar los productos a bañar.
- Segunda sección: área de bañado, en la que los productos son bañados con el chocolate:
 - Sistema de vibración y soplador, de intensidad y temperatura regulable, para remover el chocolate en exceso y facilitar las operaciones de limpieza de la red metálica.
 - Corta-colas de chocolate con velocidad y sentido de rotación variables para acabar toda tipología de producto.
 - 2 accesorios disponibles: para bañado parcial y bañado de la parte inferior del producto.
- Tercera sección: área de descarga, en la que los productos son posicionados en la respectiva bandeja.

 La tempéreuse de chocolat Chocotemper 24 peut être fournie avec **ICBELT**, un ruban recouvreur à vitesse réglable, conçu pour recouvrir des produits de pâtisserie et de pralinerie, subdivisé en 3 sections.

- Première section: zone de chargement, qui peut être arrêtée de façon à pouvoir placer les produits à recouvrir.
- Deuxième section: zone de couverture, où les produits sont recouverts de chocolat:
 - Système de vibration et souffleur d'air, à intensité et température réglables, pour ôter le chocolat en excès et faciliter les opérations de nettoyage du treillis métallique.
 - Coupe-queue à vitesse et sens de rotation variables pour finir tout type de produit.
 - 2 accessoires disponibles: le recouvreur partiel et le recouvreur de la partie inférieure du produit.
- Troisième section: zone de sortie, où les produits recouverts sont placés sur le plateau approprié.

 Das Schokoladentemperiergerät Chocotemper 24 kann mit **ICBELT**, einem Überzugsband mit einstellbarer Geschwindigkeit, geliefert werden. Es dient zur Überziehung von Konfiserie und Pralinenprodukten und ist in drei Abschnitte unterteilt.

- Erster Abschnitt: Ladebereich, der angehalten werden kann, um die zu überziehenden Erzeugnisse zu positionieren.
- Zweiter Abschnitt: Überziehbereich, in dem die Erzeugnisse mit Schokolade überzogen werden:
 - Rüttelsystem und Gebläse mit regulierbarer Stärke und Temperatur, um die überschüssige Schokolade zu entfernen und die Reinigungsarbeiten des Metallnetzes zu erleichtern.
 - Schaber mit veränderlicher Geschwindigkeit und Drehrichtung zur Vollendung aller Erzeugnisarten.
 - 2 erhältliche Zubehörteile: Maschine für teilweise Überziehänge und Überziehmaschine für die Unterseite des Erzeugnisses.
- Dritter Abschnitt: Abladebereich, in dem die überzogenen Erzeugnisse auf dem eigens vorgesehenen Blech positioniert werden.

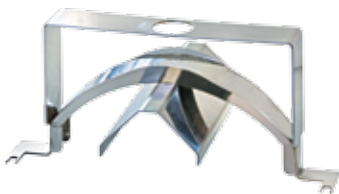

Ricopritore parziale
Partial coating
14.1.EB.PC



Ricopritore fondo
Bottom coating
14.1.EB.BC



ICBelt
14.1.EB



220/240 V



0.95 Kw



73 Kg



179x55x115h cm



22 cm



TOP TRUFFLE

MADE
IN
ITALY

Ricopritore per tartufi
Enrobing belt for truffles
Cinta de bañado para trufas
Enrobeur de truffes
Überzugsband für Trüffel

 **TOP TRUFFLE** è il nastro ricopritore per tartufi disponibile per Chocotemper 24, suddiviso in 3 sezioni:

- Prima sezione: area di carico, dove è possibile posizionare il prodotto prima della ricopritura.
- Seconda sezione: area di ricopritura, in cui i prodotti vengono ricoperti col cioccolato proveniente dalla temperatrice. L'apposito rullo permette di ricoprire anche la parte inferiore del prodotto, mentre il sistema di vibrazione permette di rimuovere il cioccolato in eccesso.
- Terza sezione: area di rifinitura. Una volta ricoperti di cioccolato, i prodotti cadono all'interno del piatto rotante riempito con cacao in polvere, scaglie di cioccolato, granelle, necessari per la realizzazione del tartufo.

 **TOP TRUFFLE** is the enrobing belt to coat truffles compatible with Chocotemper 24. It is divided into 3 sections:

- First section: loading area where products are placed before the coating step.
- Second section: enrobing area where the products are coated with chocolate coming from the tempering machine. A dedicated roll coats the bottom side of products while the vibrating mechanism removes any excess chocolate.
- Third section: trimming section. The already chocolate-coated products fall into a rotary dish with powder cocoa, chocolate flakes, ground almonds and nuts to make the truffles.

 **TOP TRUFFLE** es la cinta de bañado para trufas disponible para Chocotemper 24, subdividida en 3 secciones:

- Primera sección: área de carga, en la que es posible posicionar el producto antes del bañado.
- Segunda sección: área de bañado, en la que los productos son bañados con el chocolate procedente de la templadora. El rodillo pertinente también permite bañar la parte inferior del producto, mientras que el sistema de vibración permite remover el chocolate en exceso.
- Tercera sección: área de acabado. Una vez bañados con chocolate, los productos caen en el interior del plato giratorio lleno de cacao en polvo, chispas de chocolate, granillos, necesarios para la elaboración de la trufa.

 **TOP TRUFFLE** est le ruban recouvreur pour truffes disponibles pour Chocotemper 24, subdivisé en 3 sections:

- Première section: zone de chargement, où il est possible de placer le produit avant la couverture.
- Deuxième section: zone de couverture, où les produits sont recouverts avec le chocolat provenant de la tempéruse. Le rouleau approprié permet de recouvrir aussi la partie inférieure du produit, tandis que le système de vibration permet d'éliminer le chocolat en excès.
- Troisième section: zone de finition. Une fois recouverts de chocolat, les produits tombent à l'intérieur du plateau tournant rempli de poudre de cacao, copeaux de chocolat, pépites, qui sont nécessaires pour la réalisation de la truffe.

 **TOP TRUFFLE** ist das für Chocotemper 24 erhältliche, in 3 Abschnitte unterteilte Überziehband für Trüffel:

- Erster Abschnitt: Ladebereich, in dem das Erzeugnis vor dem Überziehen positioniert werden kann.
- Zweiter Abschnitt: Überziehbereich, in dem die Erzeugnisse mit der aus dem Temperiergerät kommenden Schokolade überzogen werden. Die eigens dafür vorgesehene Rolle ermöglicht auch das Überziehen der Unterseite des Erzeugnisses, während das Rüttelsystem die Entfernung der überschüssigen Schokolade zulässt.
- Dritter Abschnitt: Vollendungsbereich. Nach dem Überziehen mit der Schokolade fallen die Erzeugnisse in den mit Kakaopulver, Schokosplitter und Körner, die für die Herstellung des Trüffels erforderlich sind, gefüllten Drehteller.



	Top Truffle 14.1.EBT
	220/240 V
	0.24 Kw
	25 Kg
	105 cm
	22 cm
	80 cm



CHOCOHot

MADE
IN
ITALY

Colatrice di cioccolato da banco *Chocolate dispenser* Dispensadora de chocolate de banco *Couleuse de comptoir à chocolat* Schokoladenformmaschine

 **CHOCOHot** è una colatrice di cioccolato da banco, creata per essere integrata nei banconi di pasticcerie, gelaterie, cioccolaterie e può essere utilizzata per riempire coni e coppette, realizzare decorazioni, etc. La linea ChocoHot si compone di due modelli: ChocoHot One, con capacità di 5.5 kg, e ChocoHot Two, dotata di doppia vasca ognuna con capacità di 5.5 kg.

- Coclea rimovibile in acciaio inox per facilitare la pulizia e per cambiare velocemente il cioccolato utilizzato.
- Due motori indipendenti, uno per la coclea e uno per l'agitatore, per una maggiore durata nel lungo periodo.
- Possibilità di incassare la macchina nel bancone grazie al kit da incasso.
- Dosaggi automatici e possibilità di controllare il flusso di cioccolato tramite il pedale o l'apposito bottone.
- Modalità notturna per tenere il cioccolato sciolto, ma limitando il consumo durante i periodi di non utilizzo.
- Rotazione contraria della coclea, utile durante la pulizia e le operazioni di svuotamento.
- A disposizione sei beccucci speciali e mobiletti portatili, sia per ChocoHot One che per ChocoHot Two.

 **CHOCOHot** is a chocolate dispenser invented specifically for ice cream parlours and chocolate shops and can be used to top ice cream cones and tubs, to make pretty decorations, etc. ChocoHot comes in two models: ChocoHot One with a 5.5 kg bowl, and ChocoHot Two with twin bowls, 5.5 kg each.

- Removable stainless steel auger screw to facilitate cleaning the equipment and for a quick chocolate change.
- Two motors, one for the auger screw and the other for the stirrer, for enhanced motor life over the long-term.
- Thanks to a practical kit the machine can be built in the counter.
- Automatic dosing, button and pedal to control the chocolate flow.
- Night-mode to keep chocolate melted and to keep consumption under control when the equipment is not used.
- Auger screw can rotate in the opposite direction, a highly useful function to clean and empty the nozzle.
- Five special nozzles and mobile counters available for both ChocoHot One and ChocoHot Two.

 **CHOCOHot** es una dispensadora de chocolate de banco, creada para integrarse en los mostradores de pastelerías, heladerías, chocolaterías. ChocoHot se puede utilizar para llenar conos y copas, realizar decoraciones, etc. La línea ChocoHot está compuesta por dos modelos: ChocoHot One, con capacidad de 5,5 Kg, y ChocoHot Two, dotada de doble cuba cada una con capacidad de 5,5 Kg.

- Cóclea removible de acero inoxidable para facilitar la limpieza y para cambiar rápidamente el chocolate utilizado.
- Dos motores independientes, uno para la cóclea y uno para el agitador, para una mayor duración por largo tiempo.
- Posibilidad de encajar la máquina en el mostrador gracias al kit de encaje.
- Dosificaciones automáticas y posibilidad de controlar el flujo de chocolate mediante el pedal o el botón pertinente.
- Modalidad nocturna para mantener el chocolate fundido, limitando el consumo durante los lapsos de no empleo.
- Rotación contraria de la cóclea, útil durante la limpieza y para vaciar la boquilla.
- A disposición cinco boquillas especiales y aparadores portátiles.

 **CHOCOHot** est une couleuse de comptoir à chocolat, crée pour être s'intégrer aux comptoirs des pâtisseries, des glaciers, des chocolateries et peut être utilise pour remplir les cones et les coupes, réaliser des decorations, etc. La ligne ChocoHot se compose de deux modèles: ChocoHot One, avec une capacité de 5,5 Kg, et ChocoHot Two, équipé de double cuvette.

- Vis sans fin amovible en acier inox pour faciliter le nettoyage et pour changer rapidement le chocolat utilisé.
- Deux moteurs, un pour la vis sans fin et un pour l'agitateur, pour une plus grande durée dans la longue période.
- Possibilité d'encastrer la machine dans le comptoir grâce au kit d'encastrement.
- Dosages automatiques et possibilité de contrôler le flux de chocolat grâce à la pédale ou au bouton approprié.
- Modalité nocturne pour maintenir le chocolat fondu, en limitant la consommation pendant la nuit.
- Rotation contraire de la vis sans fin, utile pendant le nettoyage et pour vider le bec verseur.
- À disposition cinq becs verseurs spéciaux et les armoires portables.

 **CHOCOHot** ist eine Schokoladenformmaschine, die auf einem Gestell positioniert wird und somit in die Produktionskette zur Herstellung von Konditoreiprodukten, Eis und Schokoladenwaren integriert werden kann. Außerdem kann diese Maschine zum Füllen von Waffeltüten und Schalen genutzt werden sowie zur Herstellung von heißer Schokolade, zum Dekorieren, usw. Die Linie ChocoHot besteht aus zwei Modellen: ChocoHot One mit einem Fassungsvermögen von 5.5 Kg und ChocoHot Two mit Doppelwanne.

- Entfernbare Edelstahlschnecke für eine leichte Reinigung und für einen schnellen Wechsel der Schokolade.
- Zwei unabhängige Motoren, einer für die Schnecke und einer für das Rührwerk für eine längere Lebensdauer.
- Die Maschine kann dank des Einbau-Kits in den Arbeitstisch eingebaut werden.
- Automatische Dosierungen und mögliche Kontrolle des Schokoladenflusses mit Pedal oder der dafür vorgesehenen Knopfaste.
- Nachtmodus, damit die Schokolade aufgelöst bleibt und der Verbrauch während der Nacht eingeschränkt wird.
- Gegenläufige Rotation der Schnecke, die während der Reinigung und für die Entleerung der Tülle zweckdienlich ist.
- Fünf Spezial-Tüllen und kleine tragbare Möbelstücke sowohl erhältlich.



 **ChocoHot-One**
14.1.CHOCOHOT

 110/240 V

 0.95 Kw

 35 Kg

 39x46x83h cm

 5.5 Kg



 **ChocoHot-Two**
14.1.CHOCOHOTTWO

 110/240 V

 1.90 Kw

 65 Kg

 74x46x83h cm

 5.5 Kg x 2

ChocoHot è personalizzabile grazie a beccucci intercambiabili, ognuno con un effetto originale

ChocoHot is personalised thanks to interchangeable nozzles, each with a distinctive effect



14.1.CHOCOHot1



14.1.CHOCOHot2



14.1.CHOCOHot3



14.1.CHOCOHot4



14.1.CHOCOHot5



**Bancone mobile
per ChocoHot One**

Mobile counter
for ChocoHot One
14.1.MC

↗ 75x55x90h cm



**Bancone mobile
per ChocoHot Two**

Mobile counter
for ChocoHot Two
14.1.MC2

↗ 115x55x90h cm

**Disponibile
in diverse
colorazioni:**

Available
in different
colors:

Bianco 
White

Nero 
Black

Grigio Acciaio 
Steel Grey

Legno chiaro 
Light Wood

Legno scuro 
Dark Wood



SCIOGLICHOC

ANALOGICI

MADE
IN
ITALY

Scioglitori di cioccolato analogici
Analogue chocolate melters
Fundidores de chocolate analógicos
Cuves de fonte de chocolat analogiques
Analoge Schokoladeschmelzgeräte

 **SCIOGLICHOC ANALOGICI** sono scioglitori di cioccolato concepiti e studiati per sciogliere e mantenere in temperatura il cioccolato.

- Struttura in plastica resistente, contenitori e coperchi in acciaio inox.
- Contenitori estraibili.
- Sistema di riscaldamento a secco, senza acqua, sia sul fondo sia ai lati per garantire una temperatura omogenea.
- Termostato analogico per regolare la temperatura.
- Disponibili in varie misure e con contenitori multipli: 1,5 lt • 3,5 lt • 6 lt • 9 lt • 13,7 lt • 2x1,5 lt • 3x0,8 lt • 4x1,5 lt

 **ANALOGUE SCIOGLICHOC** are chocolate melters conceived and designed to melt and maintain the temperature of the chocolate.

- Durable plastic structure, containers and lids made of stainless steel.
- Removable containers.
- Dry (no water) heating system at both the bottom and sides to guarantee an even temperature.
- Analogue thermostat to adjust temperature.
- Available in different sizes, and with a single or several containers: 1.5 L • 3.5 L • 6 L • 9 L • 13.7 L • 2x1.5 L • 3x0.8 L • 4x1.5 L

 **SCIOGLICHOC ANALÓGICOS** son fundidores de chocolate ideados y estudiados para derretir, fundir y mantener a temperatura el chocolate.

- Estructura de plástico resistente, contenedores y tapas en acero inoxidable.
- Contenedores extraíbles.
- Sistema de calentamiento en seco, sin agua, tanto en el fondo como en los lados para garantizar una temperatura homogénea.
- Termostato analógico para regular la temperatura.
- Disponibles en varios tamaños y con contenedores múltiples: 1,5 L • 3,5 L • 6 L • 9 L • 13,7 L • 2x1,5 L • 3x0,8 L • 4x1,5 L

 **SCIOGLICHOC ANALOGIQUES** sont des cuves de fonte de chocolat conçues et étudiées pour fondre et maintenir en température le chocolat.

- Structure en plastique résistante, récipients et couvercles en acier inox.
- Récipients extractibles.
- Système de réchauffement à sec, sans eau, autant sur le fond que sur les côtés pour garantir une température homogène.
- Thermostat analogique pour régler la température.
- Disponibles en différentes mesures et avec des récipients multiples: 1,5 L • 3,5 L • 6 L • 9 L • 13,7 L • 2x1,5 L • 3x0,8 L • 4x1,5 L

 **ANALOGUE SCIOGLICHOC** sind Schokoladeschmelzgeräte, die konzipiert und entworfen wurden, um Schokolade zu schmelzen und auf der richtigen Temperatur zu halten.

- Struktur aus widerstandsfähigem Kunststoff und herausziehbare Behälter und Abdeckungen aus Edelstahl
- Herausnehmbare Behälter.
- Trockenheizung ohne Wasser sowohl auf dem Boden als auch an den Seiten, um eine homogene Temperatur zu gewährleisten.
- Analog-Thermostat zur Temperaturregulierung.
- In unterschiedlichen Größen und mit Mehrfach-Behältern erhältlich: 1.5 L • 3.5 L • 6 L • 9 L • 13.7 L • 2x1.5 L • 3x0.8 L • 4x1.5 L

Scioglitore analogico
 capacità 1,5 lt per due vasche
 Chocolate melter,
 capacity 1.5 lt x 2
 09.SC2X1.5L



Scioglitore analogico
 capacità 0,8 lt per tre vasche
 Chocolate melter,
 capacity 0.8 lt x 3
 09.SC3X0.8L

Scioglitore analogico
 capacità 1,5 lt per quattro vasche
 Chocolate melter,
 capacity 1.5 lt x 4
 09.SC4X1.5L



110/240 V

110/240 V

110/240 V



160 W

90 W

320 W



max 50°C

max 50°C

max 50°C



40.5x26x13 cm

38.5x25x12.5 cm

76x25x13 cm

Scioglitore analogico
 capacità 1,5 lt
 Chocolate melter,
 capacity 1.5 lt
 09.SC1.5L









Scioglitore analogico
 capacità 3,5 lt
 Chocolate melter,
 capacity 3.5 lt
 09.SC3.5L



Scioglitore analogico
 capacità 6 lt
 Chocolate melter,
 capacity 6 lt
 09.SC6L



	 Lt 1.5	 Lt 3.5	 Lt 6.0
	110/240 V	110/240 V	110/240 V
	80 W	80 W	130 W
	max 50°C	max 50°C	max 50°C
	26x22.5x12.5 cm	41x23.5x14 cm	40x31.5x14 cm



**Scioglitore analogico
capacità 9 lt**
Chocolate melter,
capacity 9 lt
09.SC9L



**Scioglitore analogico
capacità 13,7 lt**
Chocolate melter,
capacity 13.7 lt
09.SC13.7L

	 Lt 9.0	 Lt 13.7
	110/240 V	110/240 V
	200 W	265 W
	max 50°C	max 50°C
	43.5x38.5x14 cm	60.5x38.5x14 cm



SCIOGLICHOC

MADE IN ITALY

DIGITALI

Scioglitori di cioccolato digitali
Digital chocolate melters
Fundidores de chocolate digitales
Cuves de fonte de chocolat numériques
Digitale Schokoladeschmelzgeräte

 **SCIOGLICHOC DIGITALI** sono scioglitori di cioccolato concepiti e studiati per sciogliere e mantenere in temperatura il cioccolato.

- Struttura in plastica resistente, contenitori e coperchi in acciaio inox.
- Contenitori estraibili.
- Sistema di riscaldamento a secco, senza acqua, sia sul fondo che ai lati per garantire una temperatura omogenea.
- Termostato digitale per una regolazione accurata della temperatura.
- Sonda di rilevazione della temperatura direttamente a contatto col cioccolato.
- Disponibili in varie misure: 3,5 lt • 6 lt • 9lt • 13,7 lt

 **DIGITAL SCIOGLICHOC** are chocolate melters conceived and designed to melt and maintain the temperature of the chocolate.

- Durable plastic structure, containers and lids made of stainless steel.
- Removable containers.
- Dry (no water) heating system at both the bottom and sides to guarantee an even temperature.
- Digital thermostat to accurately adjust temperature.
- Probe in direct contact with the chocolate to detect temperature.
- Sizes available: 3.5 L • 6 L • 9 L • 13.7 L

 **SCIOGLICHOC DIGITALES** son fundidores de chocolate ideados y estudiados para derretir, fundir y mantener a temperatura el chocolate.

- Estructura en plástico resistente, contenedores y tapas en acero inoxidable.
- Contenedores extraíbles.
- Sistema de calentamiento en seco, sin agua, tanto en el fondo como en los lados para garantizar una temperatura homogénea.
- Termostato digital para una regulación cuidadosa de la temperatura.
- Sonda de detección de la temperatura directamente en contacto con el chocolate.
- Disponibles en varios tamaños: 3,5 L • 6 L • 9 L • 13,7 L

 **SCIOGLICHOC NUMÉRIQUES** sont des cuves de fonte de chocolat conçues et étudiées pour fonder et maintenir en température le chocolat.

- Structure en plastique résistante, récipients et couvercles en acier inox.
- Récipients extractibles.
- Système de réchauffement à sec, sans eau, autant sur le fond que sur les côtés pour garantir une température homogène.
- Thermostat numérique pour une régulation précise de la température.
- Sonde de relevé de la température directement en contact avec le chocolat.
- Disponibles en différentes mesures: 3,5 L • 6 L • 9 L • 13,7 L

 **DIGITALE SCIOGLICHOC** sind Schokoladeschmelzgeräte, die konzipiert und entworfen wurden, um Schokolade zu schmelzen und auf der richtigen Temperatur zu halten.

- Struktur aus widerstandsfähigem Kunststoff und herausziehbare Behälter und Abdeckungen aus Edelstahl
- Herausnehmbare Behälter.
- Trockenheizung ohne Wasser sowohl auf dem Boden als auch an den Seiten, um eine homogene Temperatur zu gewährleisten.
- Digital-Thermostat für eine genaue Regulierung der Temperatur.
- Temperaturmessfühler direkt im Kontakt mit der Schokolade.
- In verschiedenen Größen erhältlich: 3.5 L • 6 L • 9 L • 13.7 L



**Scioglitore digitale
capacità 3,5 lt**
Digital chocolate melter,
capacity 3.5 lt
09.SC3.5LD



**Scioglitore digitale
capacità 6 lt**
Digital chocolate melter,
capacity 6 lt
09.SC6LD



**Scioglitore digitale
capacità 9 lt**
Digital chocolate melter,
capacity 9 lt
09.SC9LD



**Scioglitore digitale
capacità 13,7 lt**
Digital chocolate melter,
capacity 13.7 lt
09.SC13.7LD



Lt 3.5
110/240 V

Lt 6.0
110/240 V

Lt 9.0
110/240 V

Lt 13.7
110/240 V



80 W

130 W

200 W

265 W



max 50°C

max 50°C

max 50°C

max 50°C



23x49x26 cm

32x49x26 cm

38x52x26 cm

38x70x26 cm



CARAPHOT

MADE
IN
ITALY

Scioglitori di cioccolato per gelateria
Chocolate melters for ice-cream parlour
Fundidores de chocolate para heladería
Cuves de fonte de chocolate pour glacier
Schokoladeschmelzgeräte für Eisdiele

 **CARAPHOT** è uno scioglitore di cioccolato concepito e studiato per sciogliere e mantenere in temperatura il cioccolato. All'interno di CarapHot è posizionata una carapina estraibile in cui inserire il cioccolato, salse, glasse, creme utilizzabili per operazioni come la copertura di gelati su stecco, il topping e la decorazione sia di gelati artigianali che di gelati soft, frozen yogurt, etc.

- Capacità di 7 lt.
- Altezza contenitore 25 cm, ideale per immergere a fondo i prodotti.
- Contenitore in acciaio inox rimovibile.
- Sistema di riscaldamento a secco, senza acqua, sia sul fondo sia ai lati per garantire una temperatura omogenea.
- Termostato analogico per regolare la temperatura.
- Possibilità di incassare la macchina elegantemente nel bancone grazie al kit da incasso.

 **CARAPHOT** is a chocolate melter conceived and designed to melt chocolate and keep it at a stable temperature. A removable carapine is fitted into each CarapHot to hold chocolate, sauces, icing, and creams for coating ice-cream bars, for topping and decorating artisanal ice-cream as well as soft ice-cream, frozen yogurt, etc.

- Capacity: 7 L.
- Container height: 25 cm, perfect to fully dip products.
- Removable stainless steel container.
- Dry (no water) heating system at both the bottom and sides to guarantee an even temperature.
- Analogue thermostat to adjust temperature.
- Thanks to a practical kit the machine can be elegantly built in the counter.

 **CARAPHOT** es un fundidor de chocolate concebido y estudiado para fundir y mantener el chocolate en temperatura. En el interior de CarapHot está colocada una carapina extraíble donde introducir el chocolate, salsas, glaseados, cremas utilizables para operaciones tales como bañado de helados en palito, topping y la decoración tanto de los helados artesanales como de helados soft, frozen yogurt, etc.

- Capacidad de 7 L.
- Altura contenedor 25 cm, ideal para sumergir a fondo los productos.
- Contenedor de acero inoxidable removible.
- Sistema de calentamiento en seco, sin agua, tanto en el fondo como en los lados para garantizar una temperatura homogénea.
- Termostato analógico para regular la temperatura.
- Posibilidad de encajar la máquina elegantemente en el mostrador gracias al kit de encaje.

 **CARAPHOT** est une cuve de fonte de chocolat conçue et étudiée pour fondre et maintenir en température le chocolat. À l'intérieur de CarapHot est placée une Carapina extractible dans laquelle insérer le chocolat, les sauces, les crèmes glacées, les crèmes utilisables pour des opérations comme la couverture de glaces sur bâtonnet, la sauce et la décoration autant de crèmes glacées artisanales que de glaces soft, frozen yogurt, etc.

- Capacité de 7 L.
- Hauteur récipient 25 cm, idéal pour immerger à fond les produits.
- Récipient en acier inox amovible.
- Système de réchauffement à sec, sans eau, autant sur le fond que sur les côtés pour garantir une température homogène.
- Thermostat analogique pour régler la température.
- Possibilité d'encaster la machine élégamment dans le comptoir grâce au kit d'encastrement.







 **CARAPHOT** ist ein zum Auflösen und zur Temperaturbeibehaltung der Schokolade konzipiertes und entwickeltes Auflösegerät für Schokolade.

Im CarapHot ist ein herausnehmbarer runder Behälter positioniert, in dem die Schokolade, Soßen, Glasuren und Cremes hineingegeben werden, die für Tätigkeiten wie den Überzug von Eis am Stiel, das Topping und die Dekoration sowohl von handwerklichem als auch Soft-Eis, Frozen Joghurt usw. verwendbar sind.

- Fassungsvermögen 7 L.
- Behälterhöhe 25 cm, ideal zum ganzen Eintauchen der Erzeugnisse.
- Entfernter Edelstahlbehälter.
- Trockenheizung ohne Wasser sowohl auf dem Boden als auch an den Seiten, um eine homogene Temperatur zu gewährleisten.
- Analog-Thermostat zur Temperaturregulierung.
- Die Maschine kann dank des Einbau-Kits elegant in den Arbeitstisch eingebaut werden.









 **CarapHot One**
09.CP1

	110/240 V
	0.5 Kw
	10 Kg
	31x31x30h cm
	7 Lt
	max 50°C



 **CarapHot Two**
09.CP2

	110/240 V
	1 Kw
	18 Kg
	31x57x30h cm
	7 Lt x 2
	max 50°C







WARM&SQUEEZE

MADE
IN
ITALY

Scalda-salse
Topping warmers
Calienta-aderezos
Chauffe sauce
Soßwärmer

 **WARM&SQUEEZE** è ideale per scaldare bottiglie a pressione contenenti cioccolato, salse e prodotti vari utilizzati per guarnire e decorare crepes, gelati e altri dessert. Grazie a Warm&Squeeze i prodotti contenuti nella bottiglia rimangono in temperatura e possono essere utilizzati in qualsiasi momento.

- Struttura in acciaio inox.
- Termostato analogico per regolare la temperatura.
- Sistema di riscaldamento a secco.
- Bottiglia inclusa.

 **WARM&SQUEEZE** is the perfect device to warm squeeze bottles containing chocolate, sauces and several other products used to trim and decorate crêpes, ice-creams and other desserts. Warm&Squeeze will hold the temperature of the products inside the bottle so that they can be used at any time.

- Stainless steel structure.
- Analogue thermostat to adjust temperature.
- Dry heating system.
- Bottle included.

 **WARM&SQUEEZE** es ideal para calentar botellas a presión que contienen chocolate, salsas y productos diversos empleados para adornar y decorar panqueques, helados y otros postres. Gracias a Warm&Squeeze los productos contenidos en la botella permanecen en temperatura y pueden ser utilizados en cualquier momento.

- Estructura de acero inoxidable.
- Termostato analógico para regular la temperatura.
- Sistema de calentamiento en seco.
- Botella incluida.

 **WARM&SQUEEZE** est idéal pour réchauffer des bouteilles à pression contenant du chocolat, des sauces et des produits divers utilisés pour garnir et décorer des crêpes, des crèmes glacées et d'autres desserts. Grâce à Warm&Squeeze, les produits contenus dans la bouteille restent en température et peuvent être utilisés à tout moment.

- Structure en acier inox.
- Thermostat analogique pour régler la température.
- Système de réchauffement à sec.
- Bouteille comprise.

 **WARM&SQUEEZE** ist ideal für das Erwärmen von Schokolade, Soßen, und verschiedenen für das Garnieren und Dekorieren von Crêpes, Eis und sonstigen Desserts verwendeten Erzeugnissen enthaltenden Druckflaschen. Dank Warm&Squeeze bleiben die in der Flasche enthaltenen Produkte auf Temperatur und können jederzeit verwendet werden.

- Edelstahlrahmen.
- Analog-Thermostat zur Temperaturregulierung.
- Trockenheizung.
- Inklusive Flasche.



	Warm&Squeeze One 09.WS1
	110/240 V
	200 W
	2 Kg
	1 Lt
	max 60°C



	Warm&Squeeze Two 09.WS2
	110/240 V
	400 W
	3 Kg
	1 Lt x 2
	max 60°C



	Warm&Squeeze Three 09.WS3
	110/240 V
	600 W
	4 Kg
	1 Lt x 3
	max 60°C



SPRAYCHOC

MADE
IN
ITALY

Macchina per spruzzare cioccolato
Chocolate spraying machine
Máquina para rociar chocolate
Pulvérisateur à chocolat
Maschine zum Spritzen von Schokolade

 **SPRAYCHOC** è una macchina per spruzzare il cioccolato, il surrogato e il burro di cacao. Spraychoc è la soluzione ideale per spruzzare il cioccolato su torte, stampi di cioccolato, praline, ottenendo in pochi minuti prodotti perfettamente decorati e con un aspetto accattivante.

- Disponibile in due versioni: Spraychoc Micro, singola, e Spraychoc Maxi, doppia.
- Mediante la regolazione della pressione, della quantità di cioccolato e dell'angolazione dell'ugello è possibile ottenere effetti decorativi differenti: velluto, neve, buccia d'arancia, linee, punti, etc.
- Cabina porta pistola riscaldata a temperatura regolabile per tenere il cioccolato sciolto nei periodi di non utilizzo ed evitare ostruzioni dell'ugello.
- Il compressore è fornito su richiesta.

 **SPRAYCHOC** is a machine for spraying chocolate, substitute and butter cocoa. Spraychoc is the ideal solution for spraying chocolate on cakes, chocolate moulds, pralines, enabling the creation, in just a few short minutes, of a product that is attractive and perfectly decorated.

- There are two models: Spraychoc Micro (single) and Spraychoc Maxi (double).
- Since pressure, the quantity of chocolate, and the nozzle angle can be adjusted, there is array of decoration effects possible: velvet, snow, orange peel, lines, points, etc.
- Heated gun holding enclosure with adjustable temperature so as to keep chocolate fluid when the device is not used and in that way the nozzle does not get clogged.
- The compressor is provided on request.

 **SPRAYCHOC** es una máquina para rociar chocolate, sucedáneo y manteca de cacao. Spraychoc es la solución ideal para rociar chocolate en tortas, moldes, praliné, y para obtener en pocos minutos productos decorados perfectamente y con un aspecto atractivo.

- Disponible en dos versiones: Spraychoc Micro, singular, y Spraychoc Maxi, doble.
- Mediante la regulación de la presión, de la cantidad de chocolate y del ángulo del inyector es posible obtener diferentes efectos decorativos: terciopelo, nieve, piel de naranja, líneas, puntos, etc.
- Cabina porta pistola calentada a temperatura regulable para mantener el chocolate fundido en los lapsos de no empleo y evitar obstrucciones del inyector.
- A pedido se suministra el compresor.

 **SPRAYCHOC** est une machine à pulvériser le chocolat, le succédané et le beurre de cacao. Spraychoc est la solution idéale pour pulvériser le chocolat sur les tartes, moules de chocolat, pralines, en obtenant en quelques minutes des produits parfaitement décorés et d'un aspect captivant.

- Disponible en deux versions: Spraychoc Micro, simple, et Spraychoc Maxi, double.
- Par la régulation de la pression, de la quantité de chocolat et de l'angle de la buse, il est possible d'obtenir des effets décoratifs différents: velours, neige, peau d'orange, points, lignes, etc.
- Cabine porte pistolets réchauffée à température réglable pour maintenir le chocolat fondu dans les périodes de non utilisation et éviter l'obstruction de la buse.
- Le compresseur est fourni sur demande.

 **SPRAYCHOC** ist eine Maschine zum Spritzen von Schokolade, Surrogat und Kakaobutter. Spraychoc ist die ideale Lösung zum Spritzen von Schokolade auf Torten, Schokoladeformen, Pralinen. In wenigen Minuten zaubert man perfekt dekorierte, verführerische Produkte.

- In zwei Ausführungen erhältlich: Spraychoc Micro, einzeln, und Spraychoc Maxi, doppelt.
Mit der Regulierung des Drucks, der Schokoladenmenge und des Winkels der Düse können verschiedene dekorative Effekte erzielt werden: Samt, Schnee, Orangenhaut, Tupfen, Streifen, usw.
- Kabine für Pistolenhalter, die auf die regulierbare Temperatur erwärmt wird, um die Schokolade in den Zeiträumen, in denen sie nicht gebraucht wird, aufgelöst zu halten und Verstopfungen der Düse zu verhindern.
- Der Kompressor wird auf Anfrage geliefert.



	Spraychoc Micro 09.1CHOC1
	110/240 V
	0.95 Kw
	12 Kg
	34x18x39h cm
	0.5-3.5 bar
	airmix
	1 Lt



	Spraychoc Maxi 09.1CHOC2
	110/240 V
	0.95 Kw
	22 Kg
	70x20x40h cm
	0.5-3.5 bar
	airmix
	2 x1 Lt



**Spraychoc è ideale
per spruzzare
cioccolato nella
ICBassina**

**Spraychoc is
recommended for
ICBassina**



DECOR-FREEZE

MADE
IN
ITALY

Piastra refrigerata fino a -25°C
Plate cooled up to -25°C
Placa refrigerada hasta -25°C
Plaque réfrigérée jusqu'à -25°C
Kühlplatte bis zu -25°C

 **DECOR-FREEZE** è la macchina ideale per creare decorazioni con il cioccolato, grazie alla piastra refrigerata. È sufficiente mettere del cioccolato sulla piastra e grazie alla bassa temperatura creata da Decor-Freeze, il prodotto sarà facilmente lavorabile e malleabile. Creare decorazioni col cioccolato diventerà semplice e veloce, consentendo di dare un tocco di classe in più ad ogni torta e dessert. Decor-Freeze ha moltissime applicazioni sia nel campo della pasticceria che della ristorazione, permettendo di offrire desserts sempre innovativi alla propria clientela.

- Piastra in marmo, che grazie alle sue proprietà termoconduttive, la rendono maggiormente idonea alla lavorazione del cioccolato rispetto ad una piastra in acciaio.
- Dimensioni ridotte, ideali per ogni laboratorio.
- Termostato digitale per una regolazione accurata della temperatura.
- Temperatura impostabile fino a -25°C.

 **DECOR-FREEZE**, thanks to the refrigerated plate, is the ideal machine to create decorations with chocolate. Just put the chocolate on the plate and due to the low temperature created by the machine, the product will be easily malleable and processable. Create decorations with chocolate will become easier and faster, allowing you to give and add a touch of class to each cake and dessert. Decor-Freeze has many applications in both the fields of pastry and catering, allowing you to offer your customers more and more innovative decorations.

- Thanks to the heat-conducting properties of the marble plate, it is more suitable to work chocolate than a steel plate.
- Compact in size; suits any workplace.
- Digital thermostat to accurately adjust temperature.
- Temperature can be set up to -25°C.

 **DECOR-FREEZE** es la máquina ideal para crear decoraciones con chocolate gracias a su placa refrigerada. Basta poner el chocolate templado encima de la placa y, gracias a la baja temperatura producida por la máquina, el producto será fácilmente manejable y maleable. Crear decoraciones con chocolate será simple y rápido y brindará un toque de clase extra a tartas y postres. Decor-Freeze cuenta con muchas aplicaciones tanto en el ámbito de la pastelería como en el de la restauración y permite ofrecer a los propios clientes postres siempre innovadores.

- Placa de mármol, que gracias a sus propiedades termo conductoras, la hacen particularmente idónea para la elaboración del chocolate con respecto a una placa de acero.
- Dimensiones reducidas, ideales para cualquier laboratorio.
- Termostato digital para una regulación cuidadosa de la temperatura.
- Temperatura configurable hasta -25° C.







 **DECOR-FREEZE** est la machine idéale pour créer des décorations avec du chocolat, grâce à la plaque réfrigérée. Il suffit de mettre du chocolat sur la plaque qui, grâce à la faible température créée par la machine, rendra le produit facilement manufacturable et malléable. Créer des décorations avec du chocolat deviendra simple et rapide, permettant de donner une touche de classe en plus aux gâteaux et desserts. Decor-Freeze possède de nombreuses applications dans le domaine de la pâtisserie mais aussi de la restauration et permet d'offrir des desserts toujours innovants à votre clientèle.

- Plaque en marbre, qui, grâce à ses propriétés thermo-conductrices, la rendent plus adaptée au travail du chocolat par rapport à une plaque en acier.
- Dimensions réduites, idéales pour tout laboratoire.
- Thermostat numérique pour une régulation précise de la température.
- Température réglable jusqu'à -25°C.

 **DECOR-FREEZE** ist dank der Kühlplatte, die bis auf -25°C abkühlt, die ideale Maschine für Schokoladenverzierungen. Die temperierte Schokolade wird auf die Platte gelegt und dank der niedrigen Temperatur kann das Produkt mühelos verarbeitet und geformt werden. Einfaches und schnelles Verzieren mit Schokolade, um Torten und Desserts einen Hauch Eleganz zu verleihen. Decor-Freeze kann sowohl im Konditorei-, als auch im Gaststättengewerbe eingesetzt werden, um den Gästen innovative Dessert-Kreationen anbieten zu können.

- Marmorplatte, die dank ihrer wärmeleitenden Eigenschaften besser als eine Stahlplatte für die Verarbeitung der Schokolade geeignet ist.
- Kleine Maße, ideal für jeden Arbeitsraum.
- Digital-Thermostat für eine genaue Regulierung der Temperatur.
- Bis -25°C einstellbare Temperatur.



	Decor-Freeze 16.DECOR
	220/240 V
	0.48 Kw
	27 Kg
	48x46x38h cm
	0°/-25°C



COOK-MATIC

MADE
IN
ITALY

Macchina per tartellette *Machine for tartlets* Máquina para tarteletas *Machine pour tartelettes* Törtchen-Maschine

 **COOK-MATIC** è una macchina professionale per tartellette. Cook-Matic consente di formare e cuocere tartellette di pasta frolla, salata brisèe e sfoglia. Tramite l'accoppiamento delle due piastre, Cook-Matic permette di ottenere tartellette di varie forme e dimensioni pronte per essere farcite e decorate a piacere. È sufficiente impostare la temperatura desiderata, il tempo necessario per la cottura e premere Start. Un segnale acustico avvertirà del termine della cottura. Il prodotto ottenuto avrà il gusto delle tartellette realizzate artigianalmente, ma con tempi e costi di produzione decisamente più bassi.

- Temperatura massima di 250°C.
- Possibilità di impostare una temperatura differente tra la piastra superiore e quella inferiore.
- Tempi di cottura molto rapidi: meno di 3 minuti per le tartellette più piccole.
- 34 modelli di piastre disponibili.
- Possibilità di creare piastre personalizzate.

 **COOK-MATIC** is a professional machine for tartlets. Cook-Matic allows you to form and bake tartlets with shortbread, savoury, shortcrust and puff pastry. Through the coupling of the two plates, Cook-Matic allows you to obtain tartlets of various shapes and sizes ready to be stuffed and decorated as desired. Just set the desired temperature, the time required for cooking, and press Start. An acoustic signal will tell you when it is finished cooking. The product will have the qualitative characteristics and taste of homemade tartlets, but with considerably lower production costs.

- Maximum temperature: 250°C.
- The plates can be set to have different temperatures.
- Fast cooking times: less than 3 minutes for the smallest tartlets.
- 34 plate models available.
- Possibility to make customisable plates.

 **COOK-MATIC** es una máquina para tarteletas profesional. Cook-Matic permite formar y cocinar tarteletas de pasta frolla, masa salada, masa quebrada y masa de hojaldre. Mediante el acoplamiento de las dos placas, Cook-Matic permite obtener tarteletas de distintas formas y tamaños, listas para llenar y decorar a gusto. Basta configurar la temperatura que se busca, el tiempo necesario para la cocción y presionar Start. Una señal acústica advertirá que la cocción finalizó. El producto que se obtiene tendrá las características de calidad y el gusto de las tarteletas hechas artesanalmente, pero con costes de producción definitivamente más bajos.

- Temperatura máxima de 250° C.
- Posibilidad de configurar una temperatura diferente entre la placa superior y la inferior.
- Tiempos de cocción muy rápidos: menos de 3 minutos para las tartaletas más pequeñas.
- 34 modelos de placas disponibles.
- Posibilidad de crear placas personalizadas.

 **COOK-MATIC** est une machine professionnelle pour tartelettes. Cook-Matic permet de former et de cuire des tartelettes de pâte feuilletée, sablée et brisée. Au moyen de l'accouplement des deux plaques, Cook-Matic permet d'obtenir des tartelettes de différentes formes et dimensions, prêtes à être farcies et décorées à volonté. Il suffit de programmer la température désirée, le temps de cuisson nécessaire et appuyer sur Start. Un signal acoustique informera de la fin de la cuisson. Le produit obtenu aura le goût des tartelettes réalisées artisanalement, mais avec des temps et des coûts de production résolument plus bas.

- Température maximum de 250°C.
- Possibilité de programmer une température différente entre la plaque supérieure et la plaque inférieure.
- Temps de cuisson très rapides: moins de 3 minutes pour les tartelettes plus petites.
- 34 modèles de plaques disponibles.
- Possibilité de créer des plaques personnalisées.

 **COOK-MATIC** ist eine professionelle Törtchen-Maschine. Mit Cook-Matic kann man Törtchen aus Mürbteig, gesalzenerm Teig, geriebenem Teig und Blätterteig gestalten und backen. Dank der Kopplung der zwei Platten erhält man mit Cook-Matic Törtchen in verschiedenen Formen und Größen, die beliebig gefüllt und dekoriert werden können. Man stellt die gewünschte Temperatur und die notwendige Backzeit ein und drückt den Start-Knopf. Ein akustischer Signalton meldet das Ende des Backvorgangs. Das fertige Produkt hat die Qualität und den Geschmack hausgemachter Törtchen, bei äußerst eingeschränkten Produktionskosten.

- Höchsttemperatur von 250°C.
- Einstellung von unterschiedlichen Temperaturen für die obere und untere Platte möglich.
- Sehr schnelle Garzeiten: Unter 3 Minuten für die kleineren Tartelettes.
- 34 Plattenmodelle erhältlich.
- Herstellung von personalisierten Platten möglich.



È possibile impostare due diverse temperature tra la piastra inferiore e superiore per una cottura perfetta

It is possible to set two different temperatures between the lower and upper plate for a perfect baking

	Cook Matic 07.FCTN1
	110/240 V
	3.2 Kw
	30 kg
	44x57x42h cm
	max 250°C

COOK-MATIC **PIASTRE** MADE IN ITALY

PLATES

PIASTRA 1
PLATE 1



TONDA MIGNON
MIGNON ROUND

07.FCTP1	
Ø sup - Ø up	41 mm
Ø inf - Ø low	27 mm
h	18 mm
lato - side	4 mm
fondo - bottom	4 mm
impronte - moulds	30



PIASTRA 2
PLATE 2



TONDA MEDIA FESTONATA
MEDIUM ROUND FESTOONED

07.FCTP2	
Ø sup - Ø up	49 mm
Ø inf - Ø low	38 mm
h	15 mm
lato - side	4 mm
fondo - bottom	4.5 mm
impronte - moulds	30



PIASTRA 3
PLATE 3



TONDA GRANDE FESTONATA
BIG ROUND FESTOONED

07.FCTP3	
Ø sup - Ø up	70 mm
Ø inf - Ø low	47 mm
h	19.5 mm
lato - side	4.5 mm
fondo - bottom	4 mm
impronte - moulds	13



PIASTRA 4
PLATE 4



TONDA GRANDE FESTONATA
Ø 90 mm
BIG ROUND FESTOONED Ø 90 mm

07.FCTP4	
Ø sup - Ø up	90 mm
Ø inf - Ø low	66 mm
h	20 mm
lato - side	5 mm
fondo - bottom	4 mm
impronte - moulds	9



PIASTRA 5
PLATE 5



BARCHETTA PICCOLA FESTONATA
MIGNON OVAL FESTOONED

07.FCTP5	
sup - up	67x34 mm
inf - low	52x20 mm
h	15 mm
lato - side	3.5 mm
fondo - bottom	4 mm
impronte - moulds	30



PIASTRA 6
PLATE 6



BARCHETTA GRANDE FESTONATA
BIG OVAL FESTOONED

07.FCTP6	
sup - up	79x52 mm
inf - low	35x59 mm
h	16 mm
lato - side	5 mm
fondo - bottom	4 mm
impronte - moulds	15



PIASTRA 7
PLATE 7



QUADRATA FESTONATA
SQUARE FESTOONED

07.FCTP7	
sup - up	41x41 mm
inf - low	25 mm
h	16 mm
lato - side	5 mm
fondo - bottom	4 mm
impronte - moulds	30



PIASTRA 8
PLATE 8



CUORE
HEART

07.FCTP8	
sup - up	51x46 mm
inf - low	33x30 mm
h	18 mm
lato - side	3.5 mm
fondo - bottom	3.5 mm
impronte - moulds	30



PIASTRA 9
PLATE 9



CIALDA
WAFER

07.FCTP9	
max	5.5 mm
min	2.5 mm
linee	1.5 mm





PIASTRA 10
PLATE 10



CIALDA CON CROCE
WAFFER WITH CROSS

07.FCTP10	
max	5.5 mm
min	2.5 mm
linee	1.5 mm



PIASTRA 11
PLATE 11



CONCHIGLIA
SHELL

07.FCTP11	
sup - up	50x45 mm
inf - low	39x34 mm
h	18 mm
lato - side	3.5 mm
fondo - bottom	4 mm
impronte - moulds	30



PIASTRA 12
PLATE 12



FIOCCO FESTONATA
RIBBON FESTOONED

07.FCTP12	
sup - up	65x42 mm
inf - low	46x24 mm
h	18 mm
lato - side	5 mm
fondo - bottom	4.5 mm
impronte - moulds	20



PIASTRA 13
PLATE 13



NOCE
NUT

07.FCTP13

Ø sup - Ø up	42x35 mm
h	18 mm
lato - side	3.5 mm
fondo - bottom	3.5 mm
impronte - moulds	30



PIASTRA 14
PLATE 14



TRIANGOLO FESTONATO
TRIANGLE FESTOONED

07.FCTP14

sup - up	51x51x49 mm
inf - low	32x32x29 mm
h	18 mm
lato - side	4 mm
fondo - bottom	4 mm
impronte - moulds	30



PIASTRA 15
PLATE 15



STELLA
STAR

07.FCTP15

Ø sup - Ø up	62 mm
Ø inf - Ø low	46 mm
h	18 mm
lato - side	3 mm
fondo - bottom	4 mm
impronte - moulds	20





PIASTRA 16
PLATE 16



TONDA GRANDE FESTONATA
Ø 125 mm
BIG ROUND FESTOONED Ø 125 mm

07.FCTP16	
Ø sup - Ø up	125 mm
Ø inf - Ø low	100 mm
h	21 mm
lato - side	4 mm
fondo - bottom	5.5 mm
impronte - moulds	4



PIASTRA 17
PLATE 17



WAFFLE
WAFFLE

07.FCTP17	
dim.	98x65 mm
h	28 mm
impronte - moulds	12



PIASTRA 18
PLATE 18



CUCCHIAIO
TEASPOON

07.FCTP18	
dim.	68x31 mm
h	13 mm
lato - side	4 mm
fondo - bottom	4 mm
impronte - moulds	30



PIASTRA 19
PLATE 19



TAZZINA
LITTLE CUP

07.FCTP19	
Ø sup - Ø up	62x45 mm
Ø inf - Ø low	30 mm
h	22 mm
lato - side	4 mm
fondo - bottom	4 mm
impronte - moulds	25



PIASTRA 20
PLATE 20



TORTA Ø 250 mm
CAKE Ø 250 mm

07.FCTP20	
Ø sup - Ø up	250 mm
Ø inf - Ø low	232 mm
h	19 mm
lato - side	4 mm
fondo - bottom	8 mm
impronte - moulds	1



PIASTRA 21
PLATE 21



FIORE
FLOWER

07.FCTP21	
Ø sup - Ø up	68 mm
Ø inf - Ø low	41 mm
h	22 mm
lato - side	4-5.5 mm
fondo - bottom	4 mm
impronte - moulds	13





PIASTRA 22
PLATE 22



CILINDRO MIGNON
MIGNON CYLINDER

07.FCTP22	
Ø sup - Ø up	35 mm
Ø inf - Ø low	29 mm
h	21 mm
lato - side	4 mm
fondo - bottom	4 mm
impronte - moulds	30



PIASTRA 23
PLATE 23



TONDA - Ø 60 mm,
LATI VERTICALI
ROUND - Ø 60 mm, VERTICAL SIDES

07.FCTP23	
Ø sup - Ø up	60 mm
Ø inf - Ø low	55 mm
h	16 mm
lato - side	4 mm
fondo - bottom	4 mm
impronte - moulds	13



PIASTRA 24
PLATE 24



OTTAGONO
OCTAGON

07.FCTP24	
Ø sup - Ø up	41 mm
Ø inf - Ø low	30 mm
h	21 mm
lato - side	4 mm
fondo - bottom	4 mm
impronte - moulds	30



PIASTRA 25
PLATE 25



CUPCAKE
CUPCAKE

07.FCTP25

Ø sup - Ø up	50 mm
Ø inf - Ø low	35 mm
h	21 mm
lato - side	4-5 mm
fondo - bottom	4 mm
impronte - moulds	13



PIASTRA 26
PLATE 26



NOCE LISCIA
SMOOTH NUT

07.FCTP26

sup - up	41x28 mm
h	15 mm
lato - side	3 mm
fondo - bottom	4 mm
impronte - moulds	30



PIASTRA 27
PLATE 27



QUADRATA
SQUARE

07.FCTP27

sup - up	40x40 mm
inf - low	28x28 mm
h	20 mm
lato - side	4 mm
fondo - bottom	3.5 mm
impronte - moulds	25





PIASTRA 28
PLATE 28



SCODELLA
BOWL

07.FCTP28	
Ø sup - Ø up	45 mm
Ø inf - Ø low	32 mm
h	19.5 mm
lato - side	4 mm
fondo - bottom	3.5 mm
impronte - moulds	30



PIASTRA 29
PLATE 29



CILINDRO PICCOLO
SMALL CYLINDER

07.FCTP29	
Ø	39 mm
h	17 mm
lato - side	3 mm
fondo - bottom	3.5 mm
impronte - moulds	30



PIASTRA 30
PLATE 30



CILINDRO GRANDE
BIG CYLINDER

07.FCTP30	
Ø	81 mm
h	19 mm
lato - side	4 mm
fondo - bottom	4 mm
impronte - moulds	9



PIASTRA 31
PLATE 31



MATTONCINO PICCOLO
SMALL BRICK

07.FCTP31	
dim.	50x23 mm
h	16 mm
lato - side	3.5 mm
fondo - bottom	3.5 mm
impronte - moulds	25



PIASTRA 32
PLATE 32



MATTONCINO GRANDE
BIG BRICK

07.FCTP32	
dim.	90x30 mm
h	19 mm
lato - side	4 mm
fondo - bottom	4 mm
impronte - moulds	15



PIASTRA 33
PLATE 33



MATTONCINO QUADRATO
SQUARE BRICK

07.FCTP33	
dim.	72x72 mm
h	19 mm
lato - side	4 mm
fondo - bottom	4 mm
impronte - moulds	12



PIASTRA 34
PLATE 34



FETTA DI TORTA
CAKE SLICE

07.FCTP34	
dim.	110x60 mm
h	19 mm
lato - side	4 mm
fondo - bottom	4.5 mm
impronte - moulds	14







CHECREMA

MADE
IN
ITALY

Cuocicrema
Cream-cooker
Cuece-cremas
Cuit-crème
Cremebereiter

 **CHECREMA** è un cuocicrema compatto professionale ideale per la realizzazione di una quantità moderata di prodotti sempre freschi. Sarà finalmente possibile offrire ai propri clienti la massima qualità possibile, limitando in modo sostanziale i tempi di lavorazione. Grazie alle dimensioni compatte CheCrema diventa una macchina indispensabile per pasticcerie, gelaterie e ristoranti permettendo di automatizzare e velocizzare lavorazioni che richiederebbero tempo e fatica.

- Possibilità di realizzare fino a 7 kg di crema.
- Ciclo completo di produzione: miscelazione, riscaldamento, sosta, raffreddamento, conservazione.
- Agitazione ciclica, inversa e continua, a velocità regolabile.
- Processo per crema pasticcera già preimpostato.
- Possibilità di creare e salvare le proprie ricette, le quali possono essere modificate anche durante il processo.
- Consumi energetici ridotti rispetto alle macchine tradizionali: solamente 2,5 Kw.

 **CHECREMA** is a professional compact cream-cooker, perfect to make a small quantity of always fresh products. We will finally be able to offer our clients the highest quality possible by dramatically shortening processing times. Due to its compact design CheCrema becomes an essential machine to be used in bakeries, ice-cream parlours and restaurants. Using CheCrema all processes are automated and quicker and easier than what they used to be.

- Up to 7 Kg of cream can be produced.
- Full processing cycle: Mixing, heating, hold, cooling and conservation.
- Cyclic, reverse and continuous stirring; adjustable speed.
- Pre-set process to prepare custard.
- Create and save your own recipes, and modify them even during the process.
- Lower energy consumption than with traditional machines: Only 2.5 Kw.

 **CHECREMA** es un cuoce-cremas profesional compacto, ideal para elaborar una cantidad moderada de productos siempre frescos. Finalmente será posible ofrecer a los clientes la máxima calidad posible, limitando de manera sustancial los tiempo de elaboración. Gracias a sus medidas compactas, CheCrema es una máquina indispensable para pastelerías, heladerías y restaurantes, que permite automatizar y acortar los tiempo de elaboración que insumirían tiempo y esfuerzo de otra manera.

- Posibilidad de elaborar hasta 7 Kg de crema.
- Ciclo completo de producción: mezcla, calentamiento, pausa, enfriamiento, conservación.
- Agitación cíclica, inversa y continua, con velocidad regulable.
- Proceso para crema pastelera ya pre-configurado.
- Posibilidad de crear y guardar las propias recetas, las mismas que pueden ser modificadas aun durante el proceso.
- Consumos energéticos reducidos con respecto a las máquinas tradicionales: sólo 2,5 Kw.

 **CHECREMA** est un cuit-crème compact professionnel, idéal pour la réalisation d'une quantité modérée de produits toujours frais. Vous pourrez enfin offrir à vos clients la meilleure qualité possible, en limitant considérablement les délais de réalisation. Grâce aux dimensions compactes CheCrema devient une machine indispensable pour les pâtisseries, les glaciers et les restaurants permettant d'automatiser et accélérer les processus qui requièrent du temps et de l'effort.

- Possibilité de réaliser jusqu'à 7 Kg de crème.
- Cycle complet de production: mélange, réchauffement, arrêt, refroidissement, conservation.
- Agitation cyclique, inverse et continue, à vitesse réglable.
- Processus pour crème pâtissière déjà pré-affiché.
- Possibilité de créer et sauvegarder vos propres recettes, qui peuvent être modifiées même pendant le processus.
- Consommations énergétiques réduites par rapport aux machines traditionnelles: seulement 2,5 Kw.

 **CHECREMA** ist ein kompakter professioneller Cremebereiter, ideal für die Herstellung mittlerer Mengen stets frischer Produkte. Endlich können Sie Ihren Kunden die bestmögliche Qualität bieten und gleichzeitig die dafür nötige Arbeitszeit wesentlich reduzieren. Dank seiner kompakten Ausmaße wird CheCrema zu einer unverzichtbaren Maschine für Konditoreien, Eisdielen und Restaurants für die Automatisierung und Beschleunigung zeitund arbeitsaufwändiger Vorgänge.

- Herstellung bis zu 7 Kg Creme möglich.
- Kompletter Produktionszyklus: Mischung, Erwärmung, Pause, Abkühlung, Konservierung.
- Zyklisches, umgekehrtes und kontinuierliches Rühren mit regulierbarer Geschwindigkeit.
- Schon voreingestelltes Verfahren für Konditorcreme.
- Erstellung und Speicherung der eigenen Rezepte möglich, die auch während des Verfahrens geändert werden können.
- Geringerer Stromverbrauch als die herkömmlichen Maschinen: nur 2.5 Kw.



	CheCrema 11.CC
	220/240 V
	2.5 Kw
	68 Kg
	70x52x65h cm
	7 Kg



	CheCrema V 11.CCV
	220/240 V
	2.5 Kw
	68 Kg
	45x52x80h cm
	7 Kg



DOSICREAM

MADE
IN
ITALY

Dosatrice riempitrice ad iniezione
Dosing filling machine
Dosificadora llenadora por inyección
Doseuse remplisseuse à injection
Einspritz-Dosier- und Füllgerät

 **DOSICREAM** è una dosatrice riempitrice professionale per pasticceria, creata per velocizzare il dosaggio ad iniezione di prodotti come cannoli, croissant, ciambelle, bignè, krapfen, etc con creme, confetture e cioccolato. La grande versatilità di Dosiscream è resa possibile dalla vasta gamma di accessori in grado di soddisfare ogni esigenza produttiva. Dosiscream è disponibile sia nel modello singolo che nel modello triplo, Dosiscream-3. Quest'ultima è inoltre indicata per riempire i prodotti di fronte al cliente, al fine di trasmettere una maggiore idea di freschezza della propria produzione.

- Solida struttura in acciaio inox.
- Tramoggia con capacità di 8,5 o 13 lt.
- Vari accessori disponibili: adattatori a più uscite, beccucci vari, fascia riscaldante, pedale, pistola, etc.
- Tre modalità: manuale, automatica e sequenziale.
- Facilmente lavabile, potendo rimuovere separatamente la tramoggia, gli ingranaggi, gli adattatori e gli ugelli.

 **DOSICREAM** is a professional dosing filling machine for pastry shops, created to speed up the dosage by injection for products such as cannoli, croissants, bagels, fritters, donuts with cream, jam and chocolate. The great versatility of Dosiscream is made possible by the wide range of accessories to meet any production requirement. There are two Dosiscream models: a single hopper version and a triple one called Dosiscream 3.

- Solid stainless steel structure.
- Hopper capacity: 8.5 L or 13 L.
- A set of accessories available: adaptors to several outlets, different nozzles, heating belt, pedal, gun, etc.
- Three working modes: manual, automatic and sequential.
- Easily washable, as it allows you to remove the hopper, the gears, the adapters and the nozzles separately.

 **DOSICREAM** es una dosificadora llenadora profesional para pastelería, creada para agilizar la dosificación por inyección de productos tales como rollos dulces de requesón, cruasanes, rosquillas, petisúes, berlinas con cremas, confituras y chocolate. La gran versatilidad de Dosiscream es posible gracias a la vasta gama de accesorios en condiciones de satisfacer toda exigencia de producción. Dosiscream está disponible tanto en el modelo singular como en el modelo triple, Dosiscream-3. Está última es además adecuada para rellenar los productos frente al cliente, con el objeto de transmitir una mayor idea de frescura de la producción propia.

- Sólida estructura de acero inoxidable.
- Tolva con capacidad de 8,5 ó 13 L.
- Varios accesorios disponibles: adaptadores de varias salidas, boquillas diversas, faja calentadora, pedal, pistola, etc.
- Tres modalidades: manual, automática y secuencial.
- Fácil de lavar, dado que pueden extraerse por separado la tolva, los engranajes, los adaptadores y las boquillas

 **DOSICREAM** est une doseuse remplisseuse professionnelle pour pâtisserie, créée pour rendre plus rapide le dosage à injection de produits tels que les cannoli, croissants, brioches, beignets, boules de Berlin, avec de la crème, de la confiture et du chocolat. La grande versatilité de Dosiscream est rendue possible grâce à la vaste gamme d'accessoires aptes à satisfaire toute exigence de production. Dosiscream est disponible autant dans le modèle simple que dans le modèle triple, Dosiscream-3. Ce dernier est en outre indiqué pour remplir les produits devant votre client, afin de transmettre une meilleure idée de fraîcheur de votre production.

- Solide structure en acier inox.
- Trémie avec capacité de 8,5 ou 13 L.
- Différents accessoires disponibles: des adaptateurs à plusieurs sorties, des becs verseurs, une bande chauffante, une pédale, un pistolet, etc.
- Trois modalités: manuelle, automatique et séquentielle.
- Facilement lavable, car la trémie, les engrenages, les adaptateurs et les buses sont amovibles séparément.

 **DOSICREAM** ist ein professionelles Dosier-Füllgerät für Konditoreiwaren, das dazu konzipiert worden ist, die Dosierung bei Spritzgussprodukten wie Cannoli, Croissants, Kringel, Krapfen mit Creme, Konfitüre und Schokolade zu beschleunigen. Die große Vielseitigkeit von Dosiscream ist dem zahlreichen Zubehör zu verdanken, das allen beliebigen Produktionsanforderungen gerecht wird. Dosiscream ist sowohl als Einzel- als auch als Dreifach-Modell, Dosiscream-3, erhältlich. Das Letztere ist zudem geeignet, um die Erzeugnisse vor dem Kunden zu füllen und so eine bessere Idee der Frische der eigenen Produktion zu vermitteln.

- Stabiler Edelstahlrahmen.
- Trichter mit Fassungsvermögen von 8.5 oder 13 L.
- Verschiedene Zubehörteile erhältlich: Mehrausgang-Adapter, verschiedene Tüllen, Heizbänder, Pedal, Pistole usw.
- Drei Modalitäten: manuell, automatisch und in Folge.
- Durch die Möglichkeit den Trichter, die Zahnräder, die Adapter und die Düsen einzeln zu entfernen, ist Dosiscream einfach zu reinigen.



 **Dosicream**
12.DOSI

 110/240 V

 0.18 Kw

 27 Kg

 45x30x33h cm
45x30x63h cm (8,5 lt)
45x30x73h cm (13 lt)



 **Dosicream-3**
12.DOSI3

 110/240 V

 0.54 Kw

 69 Kg

 76x43x30h cm
76x43x65h cm (8,5 lt)

DOSICREAM **ACCESSORI** MADE IN ITALY

ACCESSORIES



Gruppo tramoggia lt 8,5
Hopper group 8.5 lt
12.T1



Gruppo tramoggia lt 13
Hopper group 13 lt
12.T2



**Gruppo tramoggia
lt 8,5 per Dosicream-3**
Hopper group 8.5 lt
for Dosicream-3
12.T3

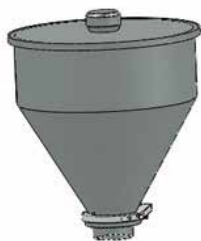

Tramoggia lt 8,5
Hopper 8.5 lt
12.T4



Tramoggia lt 13
Hopper 13 lt
12.T5



**Tramoggia lt 8,5
per Dosicream-3**
Hopper 8.5 lt for Dosicream-3
12.T6



**Adattatore tramoggia
due uscite**
Hopper adaptor with two
exits
12.A1

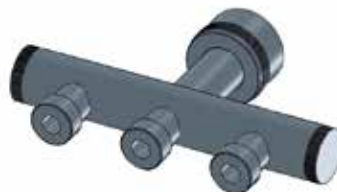

**Adattatore tramoggia
tre uscite**
Hopper adaptor with
three exits
12.A2



**Adattatore tramoggia
quattro uscite**
Hopper adaptor with four
exits
12.A3



Beccuccio Ø 10 mm
Ø 10 mm nozzle
12.N1



Beccuccio Ø 8 mm
Ø 8 mm nozzle
12.N2



Beccuccio Ø 6 mm
Ø 6 mm nozzle
12.N3



Beccuccio Ø 10 mm
per adattatore
Ø 10 mm nozzle for adaptor
12.N4



Beccuccio Ø 8 mm
per adattatore
Ø 8 mm nozzle
for adaptor
12.N5



Beccuccio Ø 6 mm
per adattatore
Ø 6 mm nozzle
for adaptor
12.N6



Beccuccio a curva
cm 25, Ø 21 mm
25 cm curved nozzle,
Ø 21 mm
12.N7



Beccuccio a curva
cm 20, Ø 21 mm
20 cm curved nozzle, Ø 21 mm
12.N8



Beccuccio a curva per
adattatore cm 8, Ø 14 mm
8 cm curved nozzle for adaptor,
Ø 14 mm
12.N9



Prolunga per maniglia
Extension for handle
12.X1

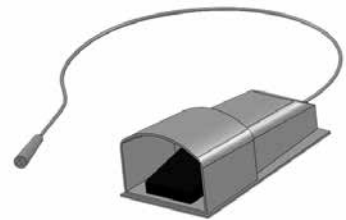

Comando pedale
per Dosicream
Pedal control for Dosicream
12.X2



Tubo prolunga Dosicream
Extension tube for Dosicream
12.X3



Tubo prolunga Dosicream
con pistola
Dosicream extension tube
with gun
12.X4

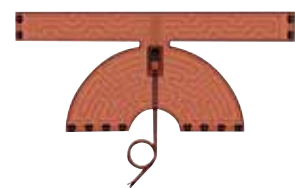

Fascia riscaldante
per tramoggia da lt 8,5
Heating belt for 8.5 lt hopper
12.X5



CHITARRA

MADE
IN
ITALY

Taglierina per cremini e torte
Cutter for chocolate creams and cakes
Cortadora para rellenos de bombón y tortas
Découpeuse pour chocolats-glacés et tartes
Schneidmaschine für Cremini und Torten

 **CHITARRA**, taglierina per pasticceria, permette di tagliare cremini a cioccolato, la sfoglia di pasta, ganache, semifreddi e prodotti di pasticceria con impasto morbido. Chitarra è disponibile in 3 diverse versioni: mini, singola e doppia.

- Solida base in alluminio.
- Telai intercambiabili in acciaio, la cui distanza tra i fili può essere di:
 - 30 e 22,5 mm per la mini chitarra.
 - 37,5 • 30 • 22,5 • 15 • 7,5 mm per la chitarra singola e quella doppia.
 - Telai di dimensioni differenti su richiesta.
- Le chitarre sono fornite con un pratico gira torte in acciaio inox e un kit per sostituire i fili.

 **GUITAR**, pastry cutter allow you to cut chocolate creams, puff pastry, ganache, frozen desserts and pastry products with soft dough. Guitar is available in 3 different versions: mini, single and double.

- Solid aluminium base
- Interchangeable stainless steel frames. Distance between the wires:
 - 30 and 22.5 mm for Mini Chitarra.
 - 37.5 • 30 • 22.5 • 15 • 7.5 mm for single and double guitar.
 - Frames available in other sizes upon request.
- The guitars are provided with a practical stainless steel cake turntable and a kit to replace the wires.

 **GUITARRA**, cortadora para pastelería permite cortar rellenos de bombón de chocolate, hoja de masa, ganache, semifríos y productos de pastelería con masa blanda.

- Sólida base de aluminio.
- Bastidores de acero intercambiables, cuya distancia entre los cables puede ser de:
 - 30 y 22,5 mm para la mini guitarra.
 - 37,5 • 30 • 22,5 • 15 • 7,5 mm para la guitarra singular y la doble.
 - Bastidores de dimensiones diferentes a solicitud.
- Las guitarras están provistas de un práctico soporte giratorio para tortas de acero inoxidable y un juego para reemplazar los cables.

 **GUITARE**, découpeuse pour pâtisserie, permet de tailler les chocolats-glacés, l'abaisse de pâte, ganache, crèmes glacées et produits de pâtisserie à pâte molle. Guitare est disponible en 3 différentes versions: mini, simple et double.

- Solide base en aluminium.
- Cadres interchangeables en acier, dont la distance entre les fils peut être de:
 - 30 et 22,5 mm pour la mini guitare.
 - 37,5 • 30 • 22,5 • 15 • 7,5 mm pour la guitare simple et la guitare double.
 - Cadres de dimensions différentes sur demande.
- Les guitares sont fournies avec un pratique plateau tournant pour gâteaux en acier inox et un kit pour remplacer les fils.

 Mit **CHITARRA** Schneidmaschine für Konfiserie, kann man Schokoladen-Cremini, Blätterteig, Ganache, Halbgefrorenes und Konfiserieprodukte aus weichem Teig schneiden.

- Stabiles Alu-Untergestell.
- Austauschbare Stahlrahmen, deren Abstand zwischen den Fäden wie folgt sein kann:
 - 30 und 22,5 mm für die Mini-Gitarre.
 - 37,5 • 30 • 22,5 • 15 • 7,5 mm für die Einzel- und Doppelgitarre.
 - Rahmen mit verschiedenen Abmessungen auf Anfrage.
- Die Chitarra werden mit einem praktischen Tortendreher aus Edelstahl und einem Set zum Austausch der Drähte geliefert.



MINI CHITARRA MINI GUITAR



Chitarra
piccola con due telai
da 30 mm e 22,5 mm
Small guitar cutter
with two frames
30 mm and 22.5 mm
13.BASE.CHIT.P

Base di taglio utile: 27x27 cm
Guitar base: 27x27 cm

CHITARRA SINGOLA SINGLE GUITAR



Base per chitarra
Single guitar base
13.BASE.CHIT

Base per chitarra
con tre telai
(13.1+13.2+13.3)
Single guitar cutter
with three frames
(13.1+13.2+13.3)
13.BASE.TELAI

Base di taglio utile: 36x36 cm
Guitar base: 36x36 cm

CHITARRA DOPPIA DOUBLE GUITAR

Base per chitarra doppia
Double guitar base
13.BASE.CHIT.D

Base per chitarra doppia
con tre telai (13.1+13.2+13.3)
Double guitar cutter
with three frames (13.1+13.2+13.3)
13.BASE.TELAI.D



Base di taglio utile: 36x36 cm
Guitar base: 36x36 cm

CARRELLO TROLLEY

Carrello Chitarra
Trolley for guitar cutters
13. CARRELLO





TELAIO GUITAR FRAME



Telaio chitarra
distanza fili 37,5 mm
Guitar frame with strings
at a distance of 37.5 mm
13.1



Telaio chitarra
distanza fili 30 mm
Guitar frame with strings
at a distance of 30 mm
13.2



Telaio chitarra
distanza fili 22,5 mm
Guitar frame with strings
at a distance of 22.5 mm
13.3



Telaio chitarra
distanza fili 15 mm
Guitar frame with strings
at a distance of 15 mm
13.4



Telaio chitarra
distanza fili 7,5 mm
Guitar frame with strings
at a distance of 7.5 mm
13.5



Macchine per gelatina
Gelatin dispensers
Rociadoras de gelatina
Machines à napper
Gelatine-Dosiergeräte

■ ■ **LINEA DIGITAL** è la gamma di erogatori di gelatina di ICB Tecnologie, ideali per spruzzare gelatina in modo ottimale. I modelli disponibili sono quattro:

- Spray Jeltop. Macchina da banco. Aspirazione diretta dal recipiente esterno della gelatina. Non permette di lavorare in continuo ma necessita di brevi pause. Ideale per piccole produzioni.
- Spray Mini Digital. Macchina da banco. Aspirazione diretta dal recipiente esterno della gelatina. Possibilità di lavorare senza pause.
- Spray Mini Digital 2,5. Macchina da banco. Aspirazione dal contenitore interno con capacità di 2,5 litri. Possibilità di lavorare senza pause.
- Spray Professional Junior Two. Macchina dotata di ruote. Aspirazione diretta dal recipiente esterno della gelatina. Possibilità di lavorare senza pause. Disponibile con due pistole, a caldo e a freddo, per due prodotti differenti.

🇬🇧 **DIGITAL LINE** is the range of gelatin dispensers from ICB Tecnologie, ideal to perfectly spray jelly. There are four models available:

- Spray Jeltop. Tabletop machine. Gelatin is directly drawn from the external container. A short pause is needed since it cannot work continuously. Perfectly suits small batches.
- Spray Mini Digital. Tabletop machine. Gelatin is directly drawn from the external container. Continuous operation.
- Spray Mini Digital 2.5. Tabletop machine. Product is drawn from the internal container with capacity of 2.5 litres. Continuous operation.
- Spray Professional Junior Two. With wheels. Gelatin is directly drawn from the external container. Continuous operation. Available with two guns (both hot and cold) for two different products.

🇪🇸 **LINEA DIGITAL** es la gama de rociadoras de gelatina de ICB Tecnologie, ideales para rociar gelatina en forma óptima. Los modelos disponibles son cuatro:

- Spray Jeltop. Máquina de mostrador. Aspiración directa del recipiente exterior de la gelatina. No permite trabajar en forma continua, son necesarias breves pausas. Ideal para pequeñas producciones.
- Spray Mini Digital. Máquina de mostrador. Aspiración directa del recipiente exterior de la gelatina. Posibilidad de trabajar sin pausas.
- Spray Mini Digital 2,5. Máquina de mostrador. Aspiración del contenedor interior con capacidad de 2,5 litros. Posibilidad de trabajar sin pausas.
- Spray Professional Junior Two. Máquina dotada de ruedas. Aspiración directa del recipiente exterior de la gelatina. Posibilidad de trabajar sin pausas. Disponible con dos pistolas, en caliente y en frío, para dos productos diferentes.

■ ■ **LINEA DIGITAL** est la gamme de distributeurs de gélatine de ICB Technologie, idéaux pour pulvériser la gélatine de façon optimale. Les modèles disponibles sont quatre:

- Spray Jeltop. Machine de table. Aspiration directe du récipient extérieur de la gélatine. Il ne permet pas de travailler en continu mais a besoin de brèves pauses. Idéal pour les petites productions.
- Spray Mini Digital. Machine de table. Aspiration directe du récipient extérieur de la gélatine. Possibilité de travailler sans pauses.
- Spray Mini Digital 2,5. Machine de table. Aspiration du récipient intérieur avec capacité de 2,5 litres. Possibilité de travailler sans pauses.
- Spray Professional Junior Two. Machine équipée de roues. Aspiration directe du récipient extérieur de la gélatine. Possibilité de travailler sans pauses. Disponible avec deux pistolets, à chaud et à froid, pour deux produits différents.

🇩🇪 **LINEA DIGITAL** ist die Produktreihe der ICB Technologie Gelatine-Dosiergeräte, ideal für das optimale Spritzen von Gelee. Es sind vier Modelle erhältlich:

- Spray Jeltop. Tischmaschine. Direktansaugung aus dem externen Geleebehälter. Lässt kein kontinuierliches Arbeiten zu, sondern benötigt kurze Pausen. Ideal für kleine Produktionen.
- Spray Mini Digital. Tischmaschine. Direktansaugung aus dem externen Geleebehälter. Pausenloses Arbeiten möglich.
- Spray Mini Digital 2.5. Tischmaschine. Ansaugung aus dem internen Behälter mit einem Fassungsvermögen von 2.5 Liter. Pausenloses Arbeiten möglich.
- Spray Professional Junior Two. Mit Rädern versehene Maschine. Direktansaugung aus dem externen Geleebehälter. Pausenloses Arbeiten möglich. Mit zwei Pistolen, Warm- und Kaltpistole, für zwei verschiedene Produkte erhältlich.



Spray Jeltop è il più piccolo erogatore professionale di gelatina

Spray Jeltop is the most compact gelatin dispenser



Spray Jeltop
08.1.AJELTOP



110/240 V



1.1 Kw



29 kg



34x45x43h cm



0.5-3.5 bar



max 90°C

Aspirazione diretta dal contenitore del prodotto
Suction direct from the gelatine containers
Aspiración directa de los recipientes de la gelatina
Aspiration directe à partir des récipients de gélatine
Saugvorgang direkt aus den Gelatinebehältern



Spray Mini digital

08.1.AMINI



110/240 V



2.7 Kw



37 kg



47x34x43h cm



0.5-3.5 bar



max 85°C



600 cc/min



Spray Mini digital con serbatoio 2,5 lt

Spray Mini digital with 2.5 lt tank

08.1.AMINIS



110/240 V



2.7 Kw



35 kg



41x30x37h cm



0.5-3.5 bar



max 85°C



600 cc/min

Aspirazione diretta dal contenitore del prodotto
 Suction direct from the gelatine containers
 Aspiración directa de los recipientes de la gelatina
 Aspiration directe à partir des récipients de gélatine
 Saugvorgang direkt aus den Gelatinebehältern



Spray Professional Junior Two con 1 tubo riscaldato

Spray Professional Junior Two
with 1 heated hose

08.1APROFJT1

Spray Professional Junior Two con 1 tubo riscaldato e tubo a freddo per baigne

Spray Professional Junior Two
with 1 heated hose
and 1 cold hose for bain-marie

08.1APROFJT2

Spray Professional Junior Two con 2 tubi riscaldati

Spray Professional Junior Two
with 2 heated hoses

08.1APROFJT3



110/240 V



2.8 Kw



63 kg



53x59x103h cm



0.5-3.5 bar



max 85°C



700 cc/min

Aspirazione diretta dal contenitore del prodotto
Suction direct from the gelatine containers
Aspiración directa de los recipientes de la gelatina
Aspiration directe à partir des récipients de gélatine
Saugvorgang direkt aus den Gelatinebehältern



PLURIGEL

MADE
IN
ITALY

Erogatori di gelatina
Gelatin dispensers
Rociadoras de gelatina
Machines à napper
Gelatine-Dosiergeräte

 **PLURIGEL** è la nuova gamma di erogatori di gelatina di ICB Tecnologie, ideali per spruzzare gelatina in modo ottimale. Gli erogatori di gelatina aspirano il prodotto direttamente dal contenitore e la gelatine viene riscaldata tramite una caldaia posta all'interno della macchina.

- Solida struttura in acciaio inox.
- Macchina da banco.
- Disponibile con due pistole, a caldo e a freddo, per due prodotti differenti.
- Aspirazione diretta dal recipiente esterno della gelatina.
- Possibilità di lavorare senza pause.
- Indicatore del livello dell'acqua nella caldaia.
- Due carrelli disponibili.

 **PLURIGEL** is the new range of gelatin dispensers from ICB Tecnologie, ideal for spraying gelatin in an optimal manner. The gelatin dispensers draw in the product directly from the container and the gelatin is heated by a boiler located inside the machine.

- Solid stainless steel structure.
- Tabletop machine.
- Available with two guns (both hot and cold) for two different products.
- Gelatin is directly drawn from the external container.
- Continuous operation.
- Water in boiler level indicator.
- Two trolleys available.

 **PLURIGEL** es la nueva gama de rociadoras de gelatina de ICB Tecnologie. Las rociadoras de gelatina aspiran el producto directamente del contenedor y la gelatina es calentada con una caldera ubicada en la máquina.

- Sólida estructura de acero inoxidable.
- Máquina de mostrador.
- Disponible con dos pistolas, en caliente y en frío, para dos productos diferentes.
- Aspiración directa del recipiente exterior de la gelatina.
- Posibilidad de trabajar sin pausas.
- Indicador del nivel del agua en la caldera.
- Dos carros disponibles.

 **PLURIGEL** est la nouvelle gamme de distributeurs de gélatine de ICB Technologie, idéaux pour pulvériser la gélatine de façon optimale. Les distributeurs de gélatine aspirent le produit directement dans le contenant et la gélatine est réchauffée au moyen d'une chaudière placée à l'intérieur de la machine.

- Solide structure en acier inox.
- Machine de table.
- Disponible avec deux pistolets, à chaud et à froid, pour deux produits différents.
- Aspiration directe du récipient extérieur de la gélatine.
- Possibilité de travailler sans pauses.
- Indicateur du niveau de l'eau dans la chaudière.
- Deux chariots disponibles.

 **PLURIGEL** è ist die neue Produktreihe der Gelee-Spender von ICB Technologie. Die Gelee-Spender saugen das Produkt direkt aus dem Behälter an die Gelatine wird mithilfe eines Heizkessels im Inneren des Geräts erwärmt.

- Stabiler Edelstahlrahmen.
- Tischmaschine.
- Mit zwei Pistolen, Warm- und Kaltpistole, für zwei verschiedene Produkte erhältlich.
- Direktansaugung aus dem externen Geleebehälter.
- Pausenloses Arbeiten möglich.
- Wasserstandsanzeige im Kessel,
- Zwei Wagen erhältlich.



**Plurigel 10
con 1 tubo riscaldato**
Plurigel 10 with 1 heated hose
15.10.1

**Plurigel 10 con 1 tubo
riscaldato e 1 tubo a freddo
per bagne**
Plurigel 10 with 1 heated hose
and 1 cold hose for bain-marie
15.10.1.1

Plurigel 10 con 2 tubi riscaldati
Plurigel 10 with 2 heated hoses
15.10.2



110/240 V



2.8 Kw



50 kg



63x54x52h cm



0.5-3.5 bar



max 85°C



700 cc/min

Aspirazione diretta dal contenitore
del prodotto
Suction direct from the gelatine
containers

Aspiración directa de los
recipientes de la gelatina
Aspiration directe à partir des
récipients de gélatine
Saugvorgang direkt aus den
Gelatinebehältern



Trolley 1 per Plurigel
Trolley 1 for Plurigel
15.10.TR1



Trolley 2 per Plurigel
Trolley 2 for Plurigel
15.10.TR2



TROLLEY 1

TROLLEY 2



13 kg

16 kg



63x54x52h cm

63x54x52h cm



SPRAY-MIX

MADE
IN
ITALY

Macchina per spruzzare l'uovo e staccanti
Machine for spraying egg and anti-stick agents
Máquina para rociar huevo y desmoldantes
Machine pour pulvériser œuf et agents de démoulage
Maschine zum Sprühen von Eiern und Trennmitteln

 **SPRAY-MIX** è una macchina spruzza uovo, indicata anche per bagne, l'olio, lo staccante per stampi o in generale per tutti i liquidi che non necessitano di essere riscaldati. Spray-Mix aspira il prodotto direttamente dal contenitore e, grazie alla perfetta nebulizzazione, viene erogato dall'operatore in modo intuitivo assicurando la massima praticità ed efficacia.

- Solida struttura in acciaio inox.
- Aspirazione diretta dal recipiente esterno del prodotto.
- La doppia regolazione, sia del flusso di aria che del flusso di liquido, garantisce il corretto mix di prodotto/aria in modo da spruzzare perfettamente.
- Compressore incluso.
- Dotata di ruote.

 **SPRAY-MIX** is an egg spraying machine, also suitable for oil baths and anti-stick agent for moulds. Spray-Mix draws in the product directly from the product container and, thanks to the perfect atomization, is intuitively dispensed by the operator, ensuring maximum practicality and effectiveness.

- Solid stainless steel structure.
- Product is directly drawn from the external container.
- The double adjustment, for both the air flow and the liquid flow, ensures that each operator can set the correct product/air mix so as to spray the egg perfectly.
- Compressor included.
- With wheels.

 **SPRAY-MIX** es una máquina para rociar huevo, indicada también para jarabes, aceite y desmoldante para moldes. Spray-Mix aspira el producto directamente del contenedor del producto y, gracias a la nebulización perfecta, éste es rociado por el usuario de manera intuitiva, lo que asegura máxima practicidad y eficacia.

- Sólida estructura de acero inoxidable.
- Aspiración directa del recipiente exterior del producto.
- La doble regulación, tanto del caudal de aire como del caudal de líquido, garantiza a cada usuario la configuración correcta de mezcla de producto/aire para rociar el huevo perfectamente.
- Compresor incluido.
- Dotada de ruedas.

 **SPRAY-MIX** est une machine qui pulvérise l'œuf, également adaptée pour les sauces, l'huile, les agents de démoulage ou en général pour tous les liquides qui n'ont pas besoin d'être réchauffés. Spray-Mix aspire le produit directement à partir du contenant du produit et, grâce à la parfaite nébulisation, est distribué par l'opérateur d'une manière intuitive, assurant le maximum de confort et d'efficacité.

- Solide structure en acier inox.
- Aspiration directe du récipient extérieur du produit.
- La double réglage de l'écoulement du liquide garantit à chaque opérateur de régler le bon mélange produit/air de façon à pulvériser l'œuf parfaitement.
- Compresseur compris.
- Équipé de roues.

 **SPRAY-MIX** ist eine Ei-Sprühmaschine, die sich für die Bäder, für Öl und das Trennmittel für Formen eignet. Spray-Mix saugt das Produkt direkt aus dem Produktbehälter an und wird dank einer perfekten Zerstäubung vom Bediener auf intuitive Weise gesendet. Dabei wird ein Höchstmaß an Komfort und Effizienz gewährleistet.

- Stabiler Edelstahlrahmen.
- Direktansaugung aus dem externen Behälter des Produkts.
- Die doppelte Einstellung, sowohl des Luftstroms als des Flüssigkeitsflusses, garantiert jedem Bediener die korrekte Einstellung der Produkt/Luft-Mischung, um ein perfektes Sprühen des Eis zu garantieren.
- Inklusive Kompressor.
- Mit Rädern versehen.



	Spray-Mix 07.7RP226
	110/240 V
	1.1 Kw
	63 kg
	68x42x113h cm
	0.5-3.5 bar
	airmix



Arrotolatrice per croissant
Croissant rolling machine
Máquina enrolladora para cruasanes
Machine enrouleuse pour croissants
Rollmaschine für Croissants

 **ROLLERO** è una macchina arrotolatrice per croissant in grado di formare velocemente croissant e prodotti simili semplicemente posizionando i triangoli di pasta sull'apposito nastro trasportatore. Sia il carico che lo scarico avvengono anteriormente, permettendo al singolo utente di controllare tutte le fasi del processo.

- Possibilità di lavorare spessori variabili da 3 a 5 mm.
- Possibilità di produrre fino a 1800 pezzi/ora.
- Nastro trasportatore rimovibile per facilitare le operazioni di pulizia.

 **ROLLERO** is a croissant rolling machine that can quickly make croissants as well as similar products just by placing a dough triangle on the dedicated conveyor belt. Just one user is required to check all the stages in the process since product goes in and out the machine on the front side.

- Compatible with different thickness from 3 to 5 mm.
- Up to 1800 pieces per hour.
- Removable conveyor belt to facilitate cleaning the equipment.

 **ROLLERO** es una máquina enrolladora para cruasanes capaz de formar rápidamente cruasanes y productos similares simplemente posicionando los triángulos de masa sobre la pertinente cinta transportadora. Tanto la carga como la descarga se producen por la delantera, permitiendo al usuario singular controlar todas las fases del proceso.

- Posibilidad de trabajar grosores variables de 3 a 5 mm.
- Posibilidad de producir hasta 1800 piezas/hora.
- Cinta transportadora removible para facilitar las operaciones de limpieza.

 **ROLLERO** est une machine enrouleuse pour croissants en mesure de former rapidement des croissants et des produits similaires, simplement en plaçant les triangles de pâte sur la bande transporteuse appropriée. Tant le chargement que le déchargement ont lieu antérieurement, permettant à chaque usager de contrôler toutes les phases du processus.

- Possibilité de travailler des épaisseurs variables de 3 à 5 mm.
- Possibilité de produire jusqu'à 1800 pièces/heure.
- Bande transporteuse amovible pour faciliter les opérations de nettoyage.

 **ROLLERO** ist eine Rollmaschine für Croissants, die in der Lage ist, schnell Croissants und ähnliche Produkte zu formen, indem einfach die Teigdreiecke auf dem dafür vorgesehenen Transportband positioniert werden. Sowohl das Ein- als auch das Ausladen erfolgen vorne und ermöglichen dem einzelnen Benutzer die Kontrolle aller Verfahrensphasen.

- Bearbeitung von veränderlichen Höhen zwischen 3 und 5 mm möglich.
- Herstellung bis zu 1800 Stück/Stunde möglich.
- Zur Erleichterung der Reinigungsarbeiten entfernbares Transportband.



	Rollero 19.RL
	220/380 V
	0.19 Kw
	23 Kg
	31x46x26h cm



Impastatrice pralinatrice
Praline mixer
Amasadora de "Pralines"
Machine pour pralines
Knet-und pralinenmaschine

 **ICBASSINA** è la macchina ideale per la ricopertura di nocciole, noci, mandorle, frutta secca con cioccolato, gianduia o caramello. Disponibile in vari modelli, con capacità di lavorazione da 3 Kg, 8 Kg e 20 Kg. Caratterizzata da una struttura solida, ICBassina permette di ottenere rapidamente praline perfette e può essere abbinata a Spraychoc, macchina per spruzzare cioccolato direttamente all'interno della bassina.

- Vasca disponibile in rame per prodotti caramellati.
- Vasca disponibile in acciaio inox per prodotti ricoperti con cioccolato.
- Sistema a gas su richiesta, ideale per effettuare la caramellizzazione.
- Regolatore di velocità (disponibile per il modello da 20 kg), per favorire una maggiore omogeneità delle praline.
- Soffiatore d'aria (disponibile per il modello da 20 kg) per velocizzare il processo in caso di grandi quantità prodotte.

 **ICBASSINA** is the ideal machine for coating hazelnuts, walnuts, almonds, dried fruit with chocolate, gianduia (soft hazelnut chocolate) or caramel. Available in several models with processing capacities of 3 Kg, 8 Kg and 20 Kg. Featuring a solid structure and, ICBassina allows you to quickly get perfect pralines and can be combined with Spraychoc, ideal machine to directly spray the chocolate into the coating pan.

- Copper bowl available for caramelized products.
- Stainless steel bowl available for chocolate-coated products.
- Gas system upon request. Perfect to caramellised processes.
- Speed regulator (available for the 20 Kg model) to enhance praline homogeneity.
- Air blower (available for the 20 Kg model) to speed up the process when large volumes are handled.

 **ICBASSINA** es la máquina ideal para recubrir avellanas, almendras, nueces, fruta seca con chocolate, gianduja y caramelo. Disponible en varios modelos, con capacidad de elaboración de 3 Kg, 8 Kg y 20 Kg. Se caracteriza por una estructura sólida, ICBassina permite obtener rápidamente bombones perfectos y se puede combinar con Spraychoc, máquina ideal para rociar chocolate directamente dentro del bombo.

- Cuba disponible en cobre para productos acaramelados.
- Cuba disponible en acero inoxidable para productos bañados con chocolate.
- Sistema a gas a solicitud, ideal para efectuar el acaramelado.
- Regulador de velocidad (disponible para el modelo de 20 Kg), para favorecer una mayor homogeneidad de las pralines.
- Soplador de aire (disponible para el modelo de 20 Kg) para acelerar el proceso en el caso de producción de grandes cantidades.

 **ICBASSINA** est la machine idéale pour l'enrobage de noisettes, noix, amandes, fruit sec avec du chocolat, du gianduja ou du caramel. Disponible en différents modèles, avec capacité de travail de 3 Kg, 8 Kg et 20 Kg. Caractérisée par une structure solide, ICBassina permet d'obtenir rapidement des pralines parfaites et peut être associée à Spraychoc, machine idéale pour saupoudrer le chocolat directement à l'intérieur de la cuvette.







- Cuve disponible en cuivre pour produits caramélisés.
- Cuve disponible en acier inox pour produits recouverts avec du chocolat.
- Système à gaz sur demande, idéal pour effectuer la caramélisation.
- Régleur de vitesses (disponible pour le modèle de 20 Kg), pour favoriser une meilleure homogénéité des pralines.
- Souffleur d'air (disponible pour le modèle de 20 Kg) pour accélérer le processus en cas de grandes quantités produites.

 **ICBASSINA** ist die ideale Maschine zum Überziehen von Haselnüssen, Walnüssen, Mandeln und Trockenfrüchten mit Schokolade, Gianduja oder Karamell. In verschiedenen Modellen mit Fassungsvermögen für die Verarbeitung von 3 Kg, 8 Kg und 20 Kg erhältlich. Mit ICBassina ist die schnelle Zubereitung perfekter Pralinen garantiert und kann mit der Spraychoc kombiniert werden, ideal um Schokolade direkt in die Bassina zu spritzen.

- Kupferwanne für Karamellprodukte erhältlich.
- Edelstahlwanne für Produkte mit Schokoladenguss erhältlich.
- Gassystem auf Anfrage, ideal für die Karamellisierung.
- Geschwindigkeitsregler (für das Modell zu 20 Kg erhältlich), um eine bessere Homogenität der Pralinen zu fördern.
- Luftgebläse (für das Modell zu 20 Kg erhältlich), um das Verfahren bei großen Produktmengen zu beschleunigen.



ICBassina
 17.ICBASSINA3
 17.ICBASSINA8
 17.ICBASSINA20

	 3 Kg	 8 Kg	 20Kg
	240 V	240 V	240 V
	0.17 Kw	0.17 Kw	0.38 Kw
	30 Kg	32 Kg	60 Kg
	53x60x74h cm	55x67x74h cm	95x58x120h cm
Attacco gas o metano Methane or gas fitting Acople para metano o gas Embout pour méthane ou gaz Methan oder Gasanschluss	✓	✓	✓
Soffiatore Blower Soplador Souffleur Bläser	-	-	✓
Variatore Speed regulator Regulator de velocidad Régulateur de vitesse Geschwindigkeitsregler	-	-	✓



**Spraychoc è ideale
 per spruzzare
 cioccolato nella
 ICBassina**

**Spraychoc is
 recommended for
 ICBassina**



MIXERS

Impastatrici planetarie - *Planetary mixers for kneading* - Amasadoras planetarias
Mélangeurs planétaires - Planetarische Knetmaschinen

■ ■ I mixer si prestano ottimamente per tutte le lavorazioni di pasticceria, panetteria e ristorazione. Sono forniti con spatola, uncino e frusta.

■ ■ The mixers are particularly suited for all processes of pastry making, bakery and catering. The kneading mixers are supplied with spatula, hook and whisk.



Mixer 7 lt
7 lt Mixer

10.VFICB7B



220 V



0.20 Kw



40x22x43 cm



7 lt

ICCREPES

MADE
IN
ITALY

Crepiere - *Crepe makers* - Panquequeras - *Crêpières* - Crêpepfannen

■ ■ **ICCREPES** è la linea di crepiere elettriche. Ideali per preparazioni sia dolci che salate, le nostre crepiere sono dotate di piastra di cottura antiaderente in ghisa, con diametro di 40 cm. Disponibili sia nella versione singola che doppia.

■ ■ **ICCREPES** is the range of electric crepe makers. Perfect to prepare sweet and salty crêpes, our crêpe makers feature a non-stick cooking cast-iron plate (Ø 40 cm). Two models: single and double.



ICcrepes One

18.CR1



230V



2.75 Kw



40 cm



ICcrepes Two

18.CR2



400/3/N V



5.5 Kw



40 cm

Stampi in silicone - *Silicone moulds* - Moldes de silicona
Moules en silicone - Silikon-Formen

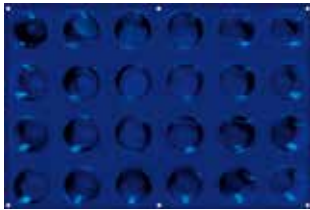

MUFFIN

IC-FLEX101	
∅	72 mm
h	40 mm
dimensione dimensions	60x40 cm
impronte moulds	24

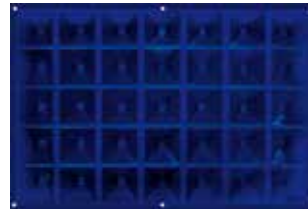

PIRAMIDE

IC-FLEX102	
∅	69x69 mm
h	46 mm
dimensione dimensions	60x40 cm
impronte moulds	35

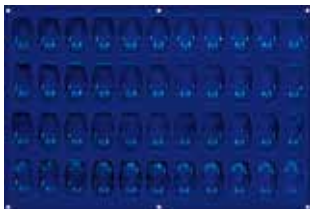

MADELEINE

IC-FLEX103	
Dim.	79x46 mm
h	19 mm
dimensione dimensions	60x40 cm
impronte moulds	40

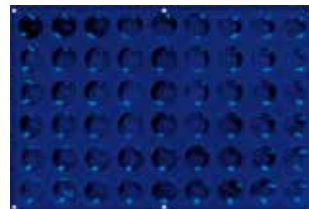

MINI MUFFIN

IC-FLEX104	
∅	50 mm
h	29 mm
dimensione dimensions	60x40 cm
impronte moulds	54

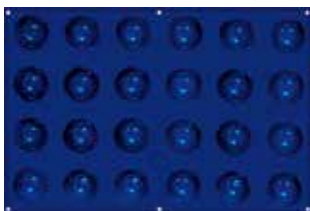

SEMISFERE

IC-FLEX106	
∅	75 mm
h	40 mm
dimensione dimensions	60x40 cm
impronte moulds	24

IC-FLEX è una linea di stampi professionali in silicone di dimensioni cm 60x40 in grado di sostituire l'utilizzo di teglie e stampi preformati. Ic-Flex possono essere utilizzati in forni ventilati, in forni a temperatura statica, in microonde, in frigorifero e freezer con temperature da -40°C a +280°C.

IC-FLEX is a line of professional silicone moulds with dimensions 60x40 cm that can replace the use of pans and preformed moulds. Ic-Flex can be used in convection ovens, static temperature ovens, microwaves, refrigerators and freezers with temperatures ranging from -40°C to +280°C.

IC-FLEX es una línea de moldes profesionales de silicona de 60x40 cm de tamaño capaz de reemplazar el empleo de bandejas para horno y moldes preformados. Los Ic-Flex pueden emplearse en hornos ventilados, hornos a temperatura estática, microondas, refrigeradores y freezers con temperaturas entre -40°C y +280°C.

IC-FLEX est une ligne de moules en silicone professionnels de dimensions 60x40 cm qui peut remplacer l'utilisation de plats et de moules préformés. Ic-Flex peuvent être utilisés dans les fours à chaleur tournante, fours à température statique, fours à micro-ondes, réfrigérateurs et congélateur sà des températures allant de -40°C à +280°C.

IC-FLEX ist eine Produktlinie professioneller Silikonformen, 60x40 cm, die Blechen und vorgeformten Formen ersetzen können. Ic-Flex, Silikon-Formen können in belüfteten Öfen, in Öfen mit statischer Temperatur, in Mikrowellenöfen, in Kühlschränken und Gefriertruhen, bei Temperaturen von -40°C bis +280°C verwendet werden.



NOVAFLON

Fogli antiaderenti in teflon
Non-stick Teflon sheets
Hojas de teflón antiadherentes
Feuilles antiadhésives en Teflon
Antihaft-Folien aus Teflon

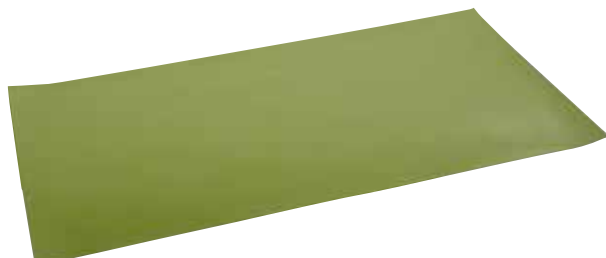



Foglio Novaflon 60x40 cm
60x40 cm Novaflon sheet
FNNF47

Foglio Novaflon 60x80 cm
60x80 cm Novaflon sheet
FNNF69





Foglio Novaflon misure personalizzate
Customized Novaflon sheet
FNNOV8

 **NOVAFLON** è la linea di fogli antiaderenti a lunga durata realizzati in teflon verde, materiale dalle ottime qualità di antiaderenza. La caratteristica principale di Novaflon è la sua resistenza che garantisce numerose cotture senza alterare la qualità dell'antiaderenza, specialmente con prodotti da forno con alta percentuale di zuccheri. I fogli di cottura in teflon si possono utilizzare a temperature che vanno da -200°C a +260°C.

 **NOVAFLON** is the line of a long-lasting non-stick sheets made of green teflon, material with excellent non-stick quality. The main characteristic of NOVAFLON is its resistance, which ensures numerous bakes without ever altering the anti-stick quality, especially with bakery products with high sugar content. The teflon baking sheets can be used at temperatures ranging from -200°C to +260°C.

 **NOVAFLON** es la línea de hojas antiadherentes de larga duración realizadas de teflón verde, material con óptima calidad antiadherente. La característica principal de Novaflon es su resistencia, la cual garantiza numerosas cocciones sin alterar la calidad antiadherente, especialmente con productos para horno con alto porcentaje de azúcares. Las hojas de cocción de teflón pueden usarse a temperaturas que varían entre -200°C y +260°C.

 **NOVAFLON** est la ligne des feuilles antiadhésives à longue durée en matériau vert téflon avec une excellente qualité antiadhésive. La principale caractéristique de Novaflon est sa résistance, qui permet de nombreuses cuissons sans altérer la qualité de l'antiadhésif, en particulier avec des produits de boulangerie à haute teneur en sucre. Les feuilles de cuisson en téflon peuvent être utilisées à des températures allant de -200 ° C à +260 ° C.

 **NOVAFLON** ist die Linie der Antihaft-Folien mit langer Lebensdauer, hergestellt aus grünem Teflon, einem Material mit optimaler Antihaft-Qualität. Die bedeutendste Eigenschaft von Novaflon ist die Widerstandsfähigkeit, die besonders bei Ofenprodukten mit einem hohen Zuckeranteil, unzählige Backvorgänge ohne Veränderung der Antihaftfähigkeit garantiert. Die Backfolien aus Teflon können bei Temperaturen von -200°C bis +260°C verwendet werden.

Carta da forno
Baking paper
Papel para hornear
Papier sulfurisé
Backfolie



Rotolo 45x200
Roll 45x200
CBSRU45

Rotolo 57x200
Roll 57x200
CBSRU57

Rotolo 40x200
Roll 40x200
CBSRU40

Carta Uni 40x60
40x60 Uni paper
CBSE46

Carta Uni 60x80
60x80 Uni paper
CBSE68

 **UNI** è una carta da forno bisiliconata di ottima qualità. La carta da forno Uni è disponibile sia in risme sia in rotoli di varie dimensioni.

 **UNI** is a top quality double-sided silicone baking paper. Uni baking paper is available in reams or in rolls of various sizes.

 **UNI** es un papel para hornear bisiliconado de óptima calidad. El papel para hornear Uni está disponible tanto en resmas como en rollos de distintos tamaños.

 **UNI** est un papier sulfurisé siliconé de qualité optimale. Le papier sulfurisé est disponible en rames ou en rouleaux de dimensions variées.

 **UNI** ist eine Doppelsilikon-Backfolie mit optimaler Qualität. Die Backfolie Uni ist sowohl in Riespackungen, als auch in verschieden großen Rollen erhältlich.



VASCHETTE GELATO

Trays for ice cream - Cubetas para helado - Cuvettes pour glace - Schalen für Eis

■ ■ Sono disponibili vaschette, bacinelle e contenitori per gelato in acciaio inox 304 adatti per le maggior parte delle vetrine di gelateria e pasticceria.

■ ■ There are trays, tubs and containers for ice cream made of 304 grade stainless steel suitable for most ice cream and pastry shop display cases.

■ ■ Se encuentran disponibles cubetas, recipientes y contenedores para helado de acero inoxidable 304 adecuados para la mayoría de las vidrieras de heladerías y pastelerías.

■ ■ Des cuvettes, bassines et contenants en glace en acier inox 304 adaptés pour la majeure partie des vitrines de glaciers et pâtisseries sont disponibles.

■ ■ Schalen, Becken und Behälter für Eis aus Edelstahl 304, die sich für die meisten der Eisdien- und Konditorei-Vitrinen eignen.



Vaschette per gelato in acciaio inox
Containers for ice cream

TEGLIE

Pans - Bandejas para horno - Plats - Backbleche

■ ■ Sono disponibili teglie di qualsiasi tipo e misura per panifici e pasticcerie. Tra queste ci sono teglie 60x40 bordo piega alluminio pieno, 60x40 bordo piega alluminio forato, 60x80 bordo piega alluminio pieno, 60x80 bordo piega alluminio forato, 60x80 alluminio forato con telaio. E' possibile contattare il nostro ufficio per preventivi personalizzati per le teglie.

■ ■ There are pans of any type and size for bakeries and pastry shops. Among these are 60x40 solid aluminum fold edge pans, 60x40 perforated aluminum fold edge, 60x80 solid aluminum fold edge, 60x80 perforated aluminum fold edge, 60x80 perforated aluminum with frame. Please contact our office for personalized quotes for pans.

■ ■ Se encuentran disponibles bandejas para horno de cualquier tipo y medida para panaderías y pastelerías. Entre las mismas hay bandejas para horno de 60x40 de borde doblado de aluminio plano, 60x40 de borde doblado de aluminio perforado, 60x80 de borde doblado de aluminio plano, 60x80 de borde doblado de aluminio perforado y 60x80 de aluminio perforado con bastidor. Es posible ponerse en contacto con nuestra oficina para presupuestos personalizados para las bandejas para horno.

■ ■ Il existe des plats de tout type et de toute taille pour boulangeries et pâtisseries. Parmi ceux-ci figurent notamment les plats de 60x40 au bord de pliage en aluminium massif, les plats de 60x40 au bord de pliage d'aluminium perforé, les plats de 60x80 au bord de pliage en aluminium massif, les plats de 60x80 au bord de pliage en aluminium perforé et les plats de 60x80 en aluminium perforé avec cadre. Veuillez contacter notre bureau pour des devis personnalisés.

■ ■ Backbleche jeglicher Art und in beliebigen stehen für Bäckereien und Konditoreien zur Verfügung. Darunter befinden sich Backbleche 60x40 Biegekante volles Aluminium, 60x40 Biegekante gelochtes Aluminium, 60x80 Biegekante volles Aluminium, 60x80 Biegekante gelochtes Aluminium, 60x80 gelochtes Aluminium mit Rahmen. Für weitere Informationen und kundenspezifische Kostenvorschläge für Backbleche, kontaktieren Sie bitte unser Büro.



**Teglia 40x60 cm alluminio
piena C/bordo piega alto 1-2 cm**
Tray aluminium 40x60 cm edge 1-2 cm
TAP010

**Teglia 60x80 cm alluminio
piena C/bordo piega alto 1-2 cm**
Tray aluminium 60x80 cm edge 1-2 cm
TAP029

Carrelli porta teglie e per forni - *Trolleys for carrying pans and for ovens*
Carros para hornos y para porta bandejas para horno - *Chariots porte-plats et pour fours*
Backblech-und Öfenwagen



**Carrelli porta teglie a
guide angolari posti 15**
Tray holders with corner
guide 15 places
CAP0001



**Carrelli in acciaio inox
"AISI 304" per forni rotativi**
Tray holders in stainless steel
"AISI 304" for rotor ovens
CAR0002S

■ ■ Sono disponibili carrelli di qualsiasi tipo e misura per panifici e pasticcerie. Tra questi ci sono carrelli porta teglie a guide angolari a 15 posti in acciaio 304 e carrelli in acciaio inox 304 per forni rotativi. E' possibile contattare il nostro ufficio per preventivi personalizzati per i carrelli.

🇬🇧 Trolleys of any type and size for bakeries and pastry shops are available. Among these are pan trolleys with angular guides with 15 places in stainless steel 304 and trolleys in 304 stainless steel for rotary ovens. Please contact our office for personalized quotes for trolleys.

🇪🇸 Se encuentran disponibles carros de cualquier tipo y medida para panaderías y pastelerías. Entre los mismos hay carros porta bandejas para horno con guías angulares de 15 pisos de acero inoxidable 304 y carros de acero inoxidable 304 para hornos rotativos. Es posible ponerse en contacto con nuestra oficina para presupuestos personalizados para los carros.

■ ■ Il existe des plats de tout type et de toute taille pour boulangeries et pâtisseries. Parmi ceux-ci figurent les chariots porte-plats à glissières angulaires à 15 places en acier 304 et les chariots en acier inox 304 pour fours rotatifs. Veuillez contacter notre bureau pour des devis personnalisés.

🇩🇪 Wagen jeglicher Art und Abmessung stehen für Bäckereien und Konditoreien zur Verfügung. Darunter befinden sich Backblechen-Wagen mit Winkelführungen und 15 Fächern aus Stahl 304 und Wagen aus Edelstahl 304 für Rotationsöfen. Für weitere Informationen und kundenspezifische Kostenvoranschläge für Wagen, kontaktieren Sie bitte unser Büro.

PRODOTTI CHIMICI

PROFESSIONALI

IGIENE GENERALE

VELOX

Detersivo liquido per pavimenti

SOLVEX

Pulitore mille usi

SANIGEL

Liquido concentrato per la pulizia delle macchine del gelato, della panna, mescolatori di granite e bibite

DISACID

Disincrostante acido, per togliere incrostazioni di latte e di calcare

SUPERLUX

Detergente pronto all'uso per pulire vetri e acciaio inox

SANICLEN

Pulitore liquido per servizi igienici, lavabili e piastrelle

LINEA FORNO

FORMENGLASUR SPECIAL SILIKOPHEN 300

Antiadesivi siliconici per stampi e teglie per la cottura in forno

SOCLEAN

Detergente liquido concentrato per la pulizia e l'igiene delle ceste di plastica dei panifici

CLEANER E CLEANER SUPER

Sgrassante potente per forni

AMBIENTE CUCINA

GLASS MATIC

Detergente liquido per lavastoviglie

BRITE MATIC/B

Additivo brillantante per il risciacquo in lavastoviglie e lavabicchieri

CALNET

Decalcificante, disincrostante per lavastoviglie e lavabicchieri

LEMON E LEMON PLUS

Liquido concentrato per il lavaggio manuale di pentole, piatti, stoviglie, bicchieri, ecc



Via Commercio, 86
25011 PONTE SAN MARCO di CALCINATO (Bs) - Italia
Tel. +39 030 9636002
Fax +39 030 9969796
E-mail: info@icbtecnologie.com
www.icbtecnologie.com