

**ecomax**<sup>TM</sup>  
by **HOBART**

# GLASS AND DISHWASHER



 made in germany

# ECOMAX OR ECOMAX PLUS – IT'S YOUR CHOICE!



**ecomax**<sup>™</sup>  
by **HOBART**

The entry-level models for those who search for a low-cost dishwasher for commercial use. Ideal for start-ups and companies with irregular washing frequency, who invest in a dishwasher for the first time. **ecomax** meets all requirements for hygienic wash results.

**ecomax**  
by **HOBART** **plus**

For mid-tier operators who seek a plus for comfort and equipment. **ecomax plus** combines all the features of an **ecomax** dishwasher and offers a plus for wash power, energy efficiency, noise reduction and ease of use.

**plus**

# OVERVIEW OF OUR MODELS

made in germany

**ecomax**<sup>™</sup>  
by **HOBART**

**Model G404 / G404 S**

Compact glasswasher



**Model G504 / G504 S**

Glasswasher



**Model F504 / F504 S**

Undercounter dishwasher



**Model H602 / H602 S**

Hood-type dishwasher



**ecomax**  
by **HOBART** **plus**

**Model G403 / G403 S**

Compact glasswasher



**Model G503 / G503 S**

Glasswasher



**Model F503 / F503 S**

Undercounter dishwasher



**Model H603 / H603 S**

Hood-type dishwasher



**plus**



## ECOMAX G404 COMPACT GLASSWASHER

*The fast and reliable glasswasher in compact design. Perfect for start-ups, small bars or restaurants.*

### FEATURES

- Electronic control with digital temperature indication for easy operation
- Rotating wash and rinse arms for an even water distribution
- Indented nozzles prevent blocking
- Integrated counter for cycles and water consumption, e.g. for control of water treatment system
- Deep drawn rack track for easy cleaning
- Incl. connection cable, supply and drain hose for immediate operation
- Thermostop function for guaranteed temperatures
- Self flushing programme to maintain hygiene within the machine
- S Version fully equipped with rinse pressure pump, class A air gap, both models with detergent and rinse aid dispenser and drain pump.





## ECOMAX PLUS G403 COMPACT GLASSWASHER

*The compact glasswasher for hotels, bars and restaurants, that are washing more than a hundred glasses a day.*

### plusFEATURES

+++ additional to ecomax +++

- + Deep-drawn wash tank for easy cleaning
- + Better energy efficiency saves operating costs
- + Double-walled housing and heat insulated front door for reduction of noise and energy losses
- + Tank strainer, coarse filter and pump suction casing secure safe operation
- + Door damping control for long life operation
- + Fully equipped with rinse pressure pump
- + Optional cabinet base for ergonomic operation





**ECOMAX G504 GLASSWASHER**  
**ECOMAX F504 DISHWASHER**

*With a high capacity of up to 60 racks per hour, this dishwasher is a reliable partner for club houses, bistros, and fast-food restaurants. The practical floor unit fits under every work counter.*

**FEATURES**

- Electronic control with digital temperature indication for easy operation
- Rotating wash and rinse arms for an even water distribution
- Indented nozzles prevent blocking
- Integrated counter for cycles and water consumption, e.g. for control of water treatment system
- Deep drawn rack track for easy cleaning
- Incl. connection cable, supply and drain hose for immediate operation
- Thermostop function for guaranteed temperatures
- Self flushing programme to maintain hygiene within the machine.
- Tank strainer reduces soiling of the tank water
- Optional cabinet base for ergonomic operation
- Fully equipped with rinse pressure pump, class A air gap, detergent and rinse aid dispenser and drain pump.





## ECOMAX PLUS G503 GLASSWASHER ECOMAX PLUS F503 DISHWASHER

*Due to the high wash power, the double-walled housing and the robust filter systems, it is the quiet and resource-saving solution for your busy workday life.*

### plusFEATURES

+++ additional to ecomax +++

- + Deep-drawn wash tank for easy cleaning
- + Better energy efficiency saves operating costs
- + Double-walled housing and heat insulated front door for reduction of noise and energy losses
- + Coarse filter secures safe operation
- + Door damping control for long life operation
- + Fully equipped with rinse pressure pump



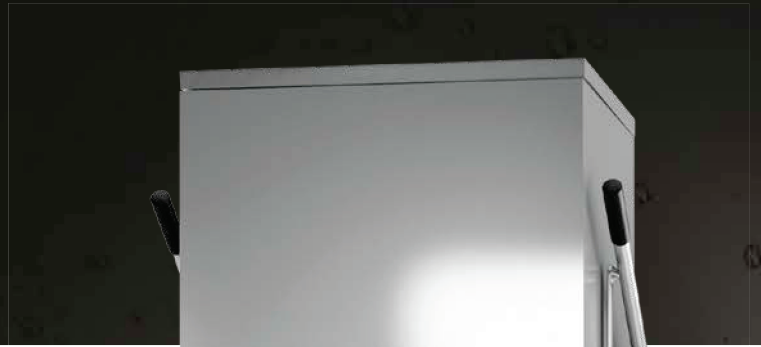

## ECOMAX H602 HOOD-TYPE DISHWASHER

*The dishwasher for ergonomic and efficient work processes in the kitchen. Combined with tables, it is a powerful partner for the catering and hotel sector.*

### FEATURES

- The 4-sided closed hood keeps energy and humidity in the system and saves up to 3 kW energy
- Deep-drawn wash tank for easy cleaning
- Rotating wash and rinse arms for an even water distribution
- Indented nozzles prevent blocking
- Incl. connection cable, supply and drain hose for immediate operation
- Thermostop function for guaranteed temperatures
- Self flushing programme to maintain hygiene within the machine
- Fully equipped with rinse pressure pump, detergent and rinse aid dispenser and drain pump.

ecomax  
H602





## ECOMAX PLUS H603 HOOD-TYPE DISHWASHER

*The dishwasher for ergonomic and efficient work processes in the kitchen. Combined with tables, it is a powerful partner for the catering and hotel sector.*

### plusFEATURES

+++ additional to ecomax +++

- + Stronger wash pump for best wash results
- + Shorter cycle times for higher capacities
- + All around ergonomic handle



**LOW PRICE**  
**HIGH PERFORMANCE**



# DRAWINGS

**ecomax™**  
by **HOBART**

Glasswasher model **G404**

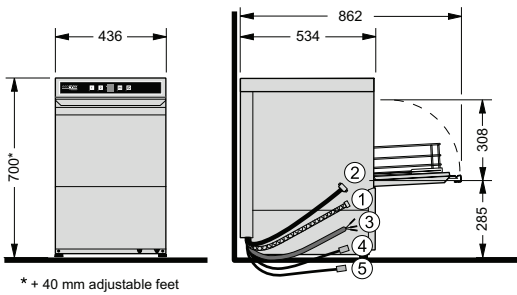

Glasswasher model **G504**  
Undercounter dishwasher model **F504**

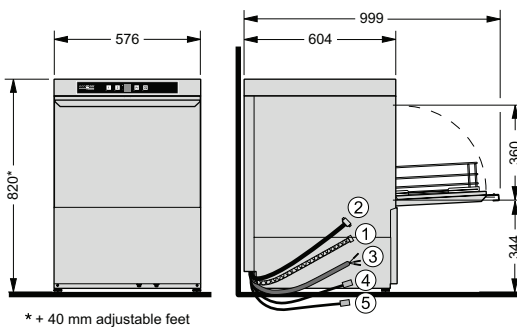

Hood-type dishwasher model **H602**

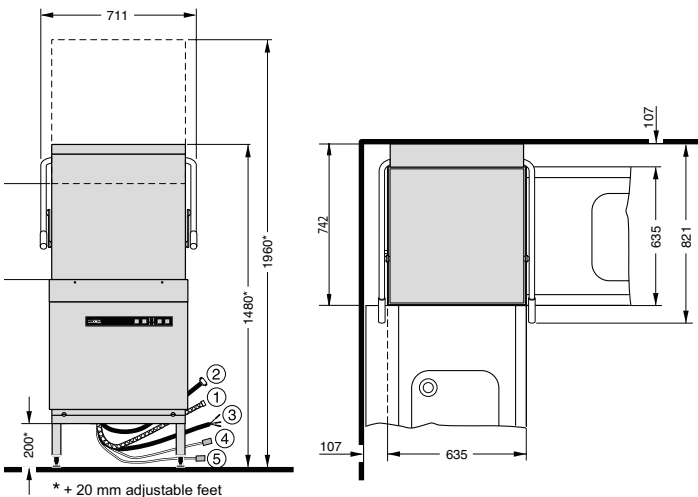

**ecomax plus**  
by **HOBART**

Glasswasher model **G403**

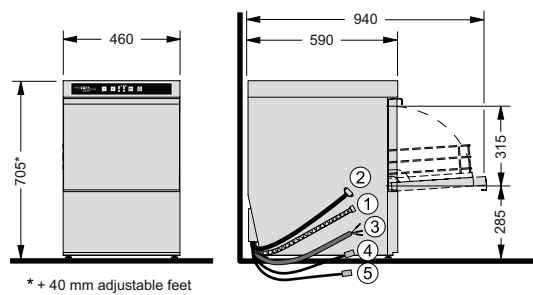

Glasswasher model **G503**  
Undercounter dishwasher model **F503**

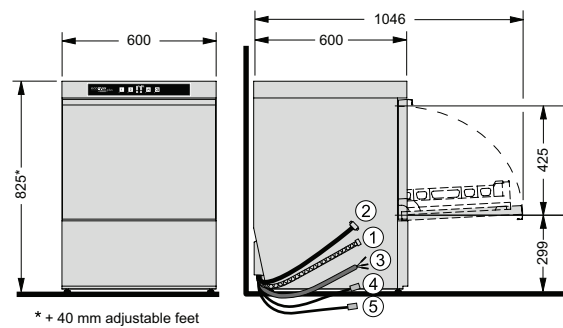

Hood-type dishwasher model **H603**

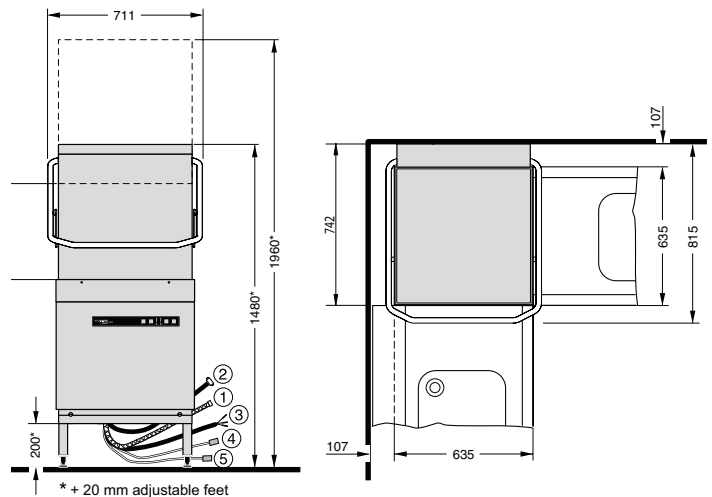

① Drain hose ② Supply hose ③ Connection cable ④ Liquid detergent <sup>a)</sup> ⑤ Rinse aid <sup>a)</sup>  
<sup>a)</sup> depending on the device chemical dispensers are not included

# FEATURES

MODELS	GLASSWASHER				plus			
	G404 -12	G404 S-12	G504 -10	G504 S-10	G403 -10	G403 S-10	G503 -11	G503 S-10
Integrated water softener*	–	●	–	●	–	●	–	●
External water treatment system**	–	–	○	○	○	○	○	○
Double-walled housing	–	–	–	–	●	●	●	●
Deep-drawn wash tank	–	–	–	–	●	●	●	●
Door damping control	–	–	–	–	●	●	●	●
Tank strainer	–	–	●	●	●	●	●	●
Drain pump	●	●	●	●	●	●	●	●
Rinse pressure pump***	–	●	●	●	●	●	●	●
Rinse aid dispenser	●	●	●	●	●	●	●	●
Detergent dispenser	●	●	●	●	●	●	●	●
Base cabinet (435 mm high) with removable door	–	–	○	○	○	○	○	○
Glass rack (sloped rows)	●	●	●	●	●	●	●	●
Glass rack (flat)	–	–	–	–	●	●	–	–
Cutlery box CB1	●	●	●	●	–	–	–	–

\* For machine protection the water hardness should not exceed 3°dH, if higher we recommend using an integrated water softener or an external water treatment system.

\*\* For use of an external water treatment system, an integrated rinse pressure pump is necessary.

\*\*\* Necessary flow pressure without rinse pressure pump: 2 - 6 bar. Flow pressure with integrated rinse pressure pump: 0.8 - 6 bar.

● Inclusive      ○ Optional

# FEATURES

made in germany

MODELS	UNDERCOUNTER DISHWASHER				HOOD-TYPE DISHWASHER			
			plus				plus	
	F504 -20	F504 S-20	F503 -10	F503 S-10	H602 -12	H602 S-12	H603 -10A	H603 S-10A
Integrated water softener*	–	●	–	●	–	●	–	●
External water treatment system**	○	–	○	–	○	–	○	○
Double-walled housing	–	–	●	●	–	–	–	–
Deep-drawn wash tank	–	–	●	●	●	●	●	●
Door damping control	–	–	●	●	–	–	–	–
Tank strainer	●	●	●	●	●	●	●	●
Drain pump	●	●	●	●	●	●	●	●
Rinse pressure pump***	●	●	●	●	●	●	●	●
Rinse aid dispenser	●	●	●	●	●	●	●	●
Detergent dispenser	●	●	●	●	●	●	●	●
HOBART tabling programme	–	–	–	–	○	○	○	○
Base cabinet (435 mm high) with removable door	○	○	○	○	–	–	–	–
Plate rack P-18-12	●	●	●	●	●	●	●	●
Cutlery box CB1	●	●	–	–	●	●	–	–
Cutlery rack with 4 boxes CB4	–	–	●	●	–	–	–	–
Universal flat rack B-00-07	–	–	●	●	–	–	●	●
Cutlery rack with 8 boxes CB8	–	–	–	–	–	–	●	●

# TECHNICAL SPECIFICATIONS

MODELS				
	G404	G504	F504	H602
Rack capacity	60 /h	60 /h	60 /h	45 /h
Tank capacity	10 l	25 l	25 l	21 l
Water consumption	2.0 l/rack	2.3 l/rack	2.3 l/rack	2.8 l/rack
Wash pump	0.18 kW	0.34 kW	0.34 kW	0.4 kW
Tank heating	1.8 kW	1.8 kW	1.8 kW	2.5 kW
<b>BOOSTER LOADING</b>				
Standard	1.9 kW (230 V)	3.7 kW (230 V)	3.7 kW (230 V)	6.2 kW (400 V)
Alternative	5.6 kW (400 V)	5.6 kW (400 V)	5.6 kW (400 V)	4.1 kW (230 V)
Alternative 2	3.7 kW (230 V)	1.9 kW (230 V)	1.9 kW (230 V)	–
<b>TOTAL CONNECTED LOAD</b>				
Standard	2.1 kW (230 V)	4.1 kW (230 V)	4.1 kW (230 V)	6.6 kW (400 V)
Alternative	5.8 kW (400 V)	5.9 kW (400 V)	5.9 kW (400 V)	4.6 kW (230 V)
Alternative 2	3.9 kW (230 V)	2.2 kW (230 V)	2.2 kW (230 V)	–
Rated voltage	230 / 50 / 1 (400 / 50 / 3N)	230 / 50 / 1 (400 / 50 / 3N)	230 / 50 / 1 (400 / 50 / 3N)	400 / 50 / 3N (230 / 50 / 1)
Width	436 mm	576 mm	576 mm	635 mm
Depth	534 mm	604 mm	604 mm	742 mm
Height	700 mm	820 mm	820 mm	1.480 (1.960) mm
Loading height	308 mm	360 mm	360 mm	440 mm
Rack size	390 x 390 mm	500 x 500 mm	500 x 500 mm	500 x 500 mm

\* The machine is equipped with an automatic cycle-time control which ensures hygienic rinse temperatures even on a cold-water supply or with reduced heating performance.

# TECHNICAL SPECIFICATIONS



MODELS	ecomax plus by HOBART			
	G403	G503	F503	H603
Rack capacity	40 /h	40 /h	40 /h	55 /h
Tank capacity	8 l	10.6 l	10.6 l	23 l
Water consumption	2.5 l/rack	2.8 l/rack	2.8 l/rack	2.8 l/rack
Wash pump	0.32 kW	0.48 kW	0.48 kW	0.7 kW
Tank heating	0.8 kW	0.8 kW	0.8 kW	2.5 kW
<b>BOOSTER LOADING</b>				
Standard	1.4 kW (230 V)	4.1 kW (230 V)	4.1 kW (230 V)	6.2 kW (400 V)
Alternative	4.2 kW (400 V)	6.2 kW (400 V)	6.2 kW (400 V)	4.1 kW (230 V)
Alternative 2	2.8 kW (230 V)	1.4 kW (230 V)	1.4 kW (230 V)	–
<b>TOTAL CONNECTED LOAD</b>				
Standard	2.7 kW	5.5 kW (230 V)	5.5 kW (230 V)	7 kW (400 V)
Alternative	5.4 kW (400 V)	7.5 kW (400 V)	7.5 kW (400 V)	4.9 kW (230 V)
Alternative 2	4.0 kW (230 V)	2.7 kW (230 V)	2.7 kW (230 V)	–
Rated voltage	230 / 50 / 1 (400 / 50 / 3N)	230 / 50 / 1 (400 / 50 / 3N)	230 / 50 / 1 (400 / 50 / 3N)	400 / 50 / 3N (230 / 50 / 1)
Width	460 mm	600 mm	600 mm	635 mm
Depth	590 mm	600 mm	600 mm	742 mm
Height	705 mm	825 mm	825 mm	1.480 (1.960) mm
Loading height	315 mm	425 mm	425 mm	440 mm
Rack size	400 x 400 mm	500 x 500 mm	500 x 500 mm	500 x 500 mm